



engineered by  
**Snap**  
av

## Installation Manual

Binary™ HDMI Matrix Switcher  
with HDMI and HDBaseT Outputs

**B-500-MTRX-230-8x16 B-500-MTRX-230-16x16**





# 1. Important Safety Instructions

**Warning:** To reduce the risk of fire or electric shock, do not expose this apparatus to rain or moisture. Do not remove cover. No user serviceable parts inside. Refer servicing to qualified service personnel.

1. Read and follow all instructions and warnings in this manual. Keep for future reference.
2. Do not use this apparatus near water.
3. Clean only with a dry cloth.
4. Do not block any ventilation openings. Install according to manufacturer's instructions.
5. Do not install near any heat sources such as radiators, heat registers, stoves or other apparatus (including amplifiers) that produce heat.
6. Do not override the safety purpose of the polarized or grounding-type plug. A polarized plug has two blades - one wider than the other. A grounding type plug has two blades and a third grounding prong. The wide blade or the third prong is provided for your safety. If the provided plug does not fit into your outlet, consult an electrician for replacement of the obsolete outlet.
7. Protect the power cord from being walked on or pinched particularly at plug, convenience receptacles, and the point where it exits from the apparatus.
8. Only use attachments/accessories specified by the manufacturer.
9. Refer all servicing to qualified service personnel. Servicing is required when the apparatus has been damaged in any way, such as when the power-supply cord or plug is damaged, liquid has been spilled or objects have fallen into the apparatus, the apparatus has been exposed to rain or moisture, does not operate normally, or has been dropped.
10. DO NOT EXPOSE THIS EQUIPMENT TO DRIPPING OR SPLASHING AND ENSURE THAT NO OBJECTS FILLED WITH LIQUIDS, SUCH AS VASES, ARE PLACED ON THE EQUIPMENT.
11. TO COMPLETELY DISCONNECT THIS EQUIPMENT FROM THE AC MAINS, DISCONNECT THE POWER SUPPLY CORD PLUG FROM THE AC RECEPTACLE.
12. THE MAINS PLUG OF THE POWER SUPPLY CORD SHALL REMAIN READILY OPERABLE.

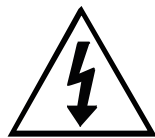

The lightning flash with arrowhead symbol, within an equilateral triangle, is intended to alert the user to the presence of un-insulated dangerous voltage within the product's enclosure that may be of sufficient magnitude to constitute a risk of electric shock to persons.



The exclamation point within an equivalent triangle is intended to alert the user to the presence of important operating and maintenance (servicing) instructions in the literature accompanying the appliance.

## Table of Contents

<b>1. Important Safety Instructions</b>	<b>2</b>
<b>2. Product Overview</b>	<b>5</b>
<b>3. Package Contents</b>	<b>5</b>
<b>4. Features</b>	<b>5</b>
<b>5. Recommended for Installation</b>	<b>5</b>
<b>6. Device Layout</b>	<b>6</b>
6.1. Front Panel	6
6.2. Rear Panel	7
<b>7. Installation and Setup</b>	<b>8</b>
7.1. Basic Installation Diagram	8
7.2. Basic Instructions	9
7.3. Installation Tips	9
7.4. Switcher Location and Placement	10
7.4.1. Rack Installation	10
7.5. HDMI Input Connections	11
7.6. Output Connections	11
7.6.1. Choosing the Correct Output	11
7.6.2. HDMI Outputs	11
7.6.3. HDBaseT Outputs	12
7.7. Matrix Control Connections	13
7.7.1. IR Control	13
7.7.2. RS232 Control	13
7.7.3. Ethernet/IP Control	13
7.8. IR Pass-Through Installation and Setup	14
7.8.1. Matrix Switcher IR Connections	14
7.8.2. Matrix Switcher IR Port Configuration	14
7.9. B-500-RX-230-IR IR Connections	15
7.9.1. IR Receiver	15
7.9.3. IR Flasher	15
7.9.3. Installation and Setup	15
7.10. IR Application Diagrams	16
7.10.1. IR Pass-Through from Control System	16
7.10.2. IR Pass-Through from Rooms to Sources	17
<b>8. EDID Configuration</b>	<b>18</b>
8.1. Source Setup	18
8.2. Display Setup	18
8.3. Auto EDID Configuration	18
8.3.1. How to Configure Auto EDID	18
8.4. Embedded EDID Configuration	19
8.4.1. Embedded EDID Chart	19
8.4.2. How to Set Embedded EDID for a Single Input	20
8.4.3. How to Set Embedded EDID for All Inputs	20
8.5. EDID Learning	20
8.5.1. How to Learn EDID to a Single Input	20
8.5.2. How to Learn EDID to a All Inputs	21
8.6. Viewing Input EDID Status	21
<b>9. Advanced Setup Using the Configuration Utility</b>	<b>22</b>
9.1. IR Source Routing	22
9.2. IR Front Panel IR Enable	22
9.3. Matrix Control from Room Enable	22
9.4. Front Panel Power Button Active	22
<b>10. Firmware Update</b>	<b>22</b>
<b>11. Operation and Control</b>	<b>23</b>
11.1. IR Remote	23
11.1.1. Route Inputs to Outputs	23
11.1.2. Turn Off (Mute) Outputs	24
11.1.3. Display Output Status	24
11.1.4. Resetting to Factory Defaults	25
<b>12. Troubleshooting</b>	<b>26</b>
12.1. General Troubleshooting Guidelines	26
12.2. No Signal from Source to any Display	26
12.3. No Signal from any Source to any Display	26
12.4. Audio issues	27
<b>13. Contacting Tech Support</b>	<b>27</b>
<b>14. System Layout Chart</b>	<b>28</b>
<b>15. Specifications</b>	<b>30</b>
<b>16. Warranty</b>	<b>30</b>

## 2. Product Overview

Welcome to Binary™, one of the most highly regarded brands available today. This product is engineered to provide years of exceptional reliability. We appreciate your business and we stand committed to providing our customers with the highest degree of quality and service in the industry.

The B-500-MTRX-230-8X16/16X16 is a state-of-the-art HDMI matrix switcher with both HDMI and HDBaseT Outputs. It provides true matrix routing for HDMI signals. With features such as HDMI 3D support, sophisticated EDID handling, and IR, RS232 and Ethernet control, this product is ideal for residential and commercial media distribution systems. The HDBaseT connection on each output extends HDMI signal and bi-directional IR to remote rooms up to 230 feet away via Cat5e/Cat6/Cat6a.

**Note:** This manual covers all aspects of installation and setup of the B-500-MTRX-230-8X16/16X16. Some features must be configured using the Configuration Utility software. Go to the product page for the B-500-MTRX-230-8X16/16X16 at [www.SnapAV.com](http://www.SnapAV.com) and click on the Support Tab to download the Configuration Utility and manual.

## 3. Package Contents

- (1) B-500-MTRX-230-8x16 / 16x16
- (2) Rack ears for mounting (screws included)
- (1) IR Remote Control
- (1) Power supply 12V DC, 11.25A
- (1) Installation Manual
- (1) CD-ROM (Configuration Utility)

## 4. Features

- (8) or (16) HDMI inputs by (16) mirrored HDMI and HDBaseT outputs
- Up to 32 displays can be attached in total (using both HDMI and HDBaseT outputs)
- Supports Video resolutions up to 1080p/60 36bit color
- Supports all HDMI audio formats including Dolby True HD and DTS Master HD
- Supports all HDMI 3D formats
- Sophisticated EDID handling including Embedded, Learned, and Auto modes
- HDMI or DVI with adapter (not included)
- IR Control from integrated receiver or 3.5mm input
- Bi-directional IR pass-through when using B-500-RX-230-IR
- Home Automation Control via IR, RS-232 and Ethernet
- PC Setup and Configuration using dedicated software
- HDCP 2.0 compliant
- CEC Pass Through

## 5. Recommended for Installation

- Phillips Screwdriver (for rack ear attachment)
- Up to 8 sources (16 if using the B-500-MTRX-230-16X16)
- Up to 16 displays (32 if using both HDBaseT and HDMI outputs, see Section 7.6, Page 11)
- Binary High Speed HDMI Cables to connect sources to B-500-MTRX-230 HDMI inputs
- Binary HDMI cables or B-500-RX-230-IR units and Cat 5e/6 cable installed between matrix switcher location and displays (See section 7.6.3.1, page 12 for HDBaseT wiring recommendations)
- RJ45 connectors and termination tools (If using B-500-RX-230-IR)
- Control System or programmable IR remote to control operation of B-500-MTRX-230
- Windows PC with Configuration Utility installed and RS232 adapter
- Configuration Utility Manual

## 6. Device Layout

### 6.1. Front Panel

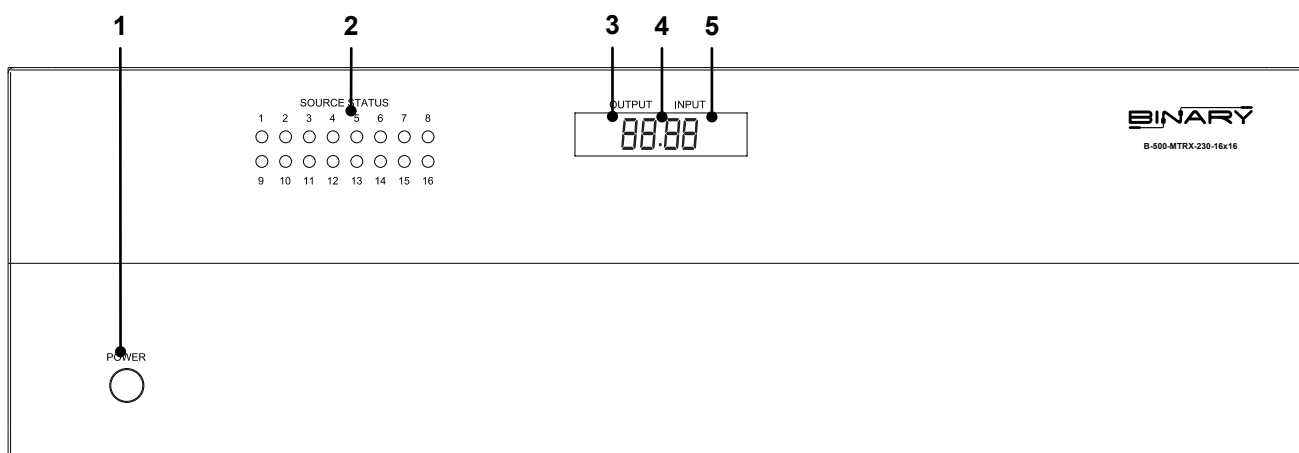

1. **Power On/Off Switch**  
Toggle Power from On to Stand-by. Can be disabled from Configuration Utility software.
2. **Source Status LEDs**  
Indicates that the selected source is on and transmitting an HDMI signal.
3. **Output Display**  
Displays the last output selected.
4. **IR Receiver Window**  
IR receiver for Matrix to capture commands sent by IR remote.
5. **Input Display**  
Displays the last input selected.

## 6.2. Rear Panel

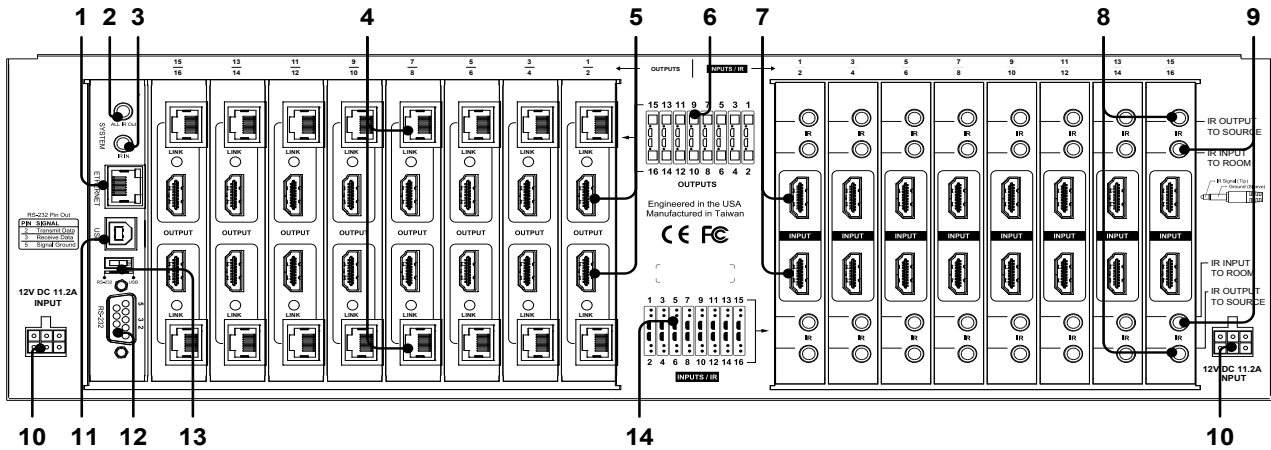

1. **Ethernet Port**  
RJ45 port for connecting an Ethernet Cat5e/6 cable for IP control of the B-500-MTRX-230.
2. **System All IR Out**  
3.5mm mono mini port, repeats all IR commands from all connected HDBaseT outputs (from IR Receiver port of B-500-RX-230-IR).
3. **System IR In**  
3.5mm mono mini IR input port for matrix control.
4. **HDBaseT Outputs 1 through 16 (RJ45)**  
Connect 568B terminated Cat5e/6 HDBaseT cable routed to a B-500-RX-230-IR to feed HDMI signal to display. Output simultaneously displays the same source as the HDMI output of the same number. Odd numbered outputs are at the top and even numbered outputs are at the bottom.
5. **HDMI Outputs 1 through 16**  
Connect HDMI cables to route to displays. Output simultaneously displays the same source as the HDBaseT output of the same number. Odd numbered outputs are at the top and even numbered outputs are at the bottom.
6. **Output Number Legend**  
Printed diagram to indicate output numbering.
7. **HDMI Inputs 1 through 8 (or 16)**  
Connect HDMI cables from sources to the matrix switcher for distribution. Odd numbered outputs are at the top and even numbered outputs are at the bottom.
8. **IR Output to Source 1 through 8 (or 16)**  
Blue 3.5mm mono mini ports are used to connect IR flashers for controlling sources. These ports may be set to route commands only from the IR output corresponding to the HDBaseT output number (IR zone routing), or directly to the source selected on an HDBaseT output (IR source routing). Odd numbered outputs are at the top and even numbered outputs are at the bottom. See Section 9.1. IR Source Routing on page 22 for routing setup.
9. **IR Input to Room**  
Green 3.5mm mono mini ports are used to route IR commands to the B-500-RX-230-IR IR Flasher port connected to each respective output. Use these connections to control displays or other equipment from the matrix location. Odd numbered outputs are at the top and even numbered outputs are at the bottom.
10. **Redundant Power Jacks**  
Dual polarized, 12V DC 11.25A power connections. Connect the power supply on whichever side is more convenient.
11. **USB Port**  
Reserved for future use.
12. **RS-232 Control (DB9)**  
Attach connection from control system or Windows PC for serial control of the B-500-MTRX-230. Update firmware on the matrix switcher.
13. **USB/RS232 Toggle Switch**  
USB firmware update switch for main board updates. *Must be set to RS232 for normal operation.*
14. **Input Number Legend**  
Printed diagram to indicate input and IR connection numbering.

## 7. Installation and Setup

### 7.1. Basic Installation Diagram

Complete the basic installation section to set up the matrix switcher for media distribution before completing any other setup. Use this diagram for reference during basic installation of the matrix switcher, sources, displays and wiring.

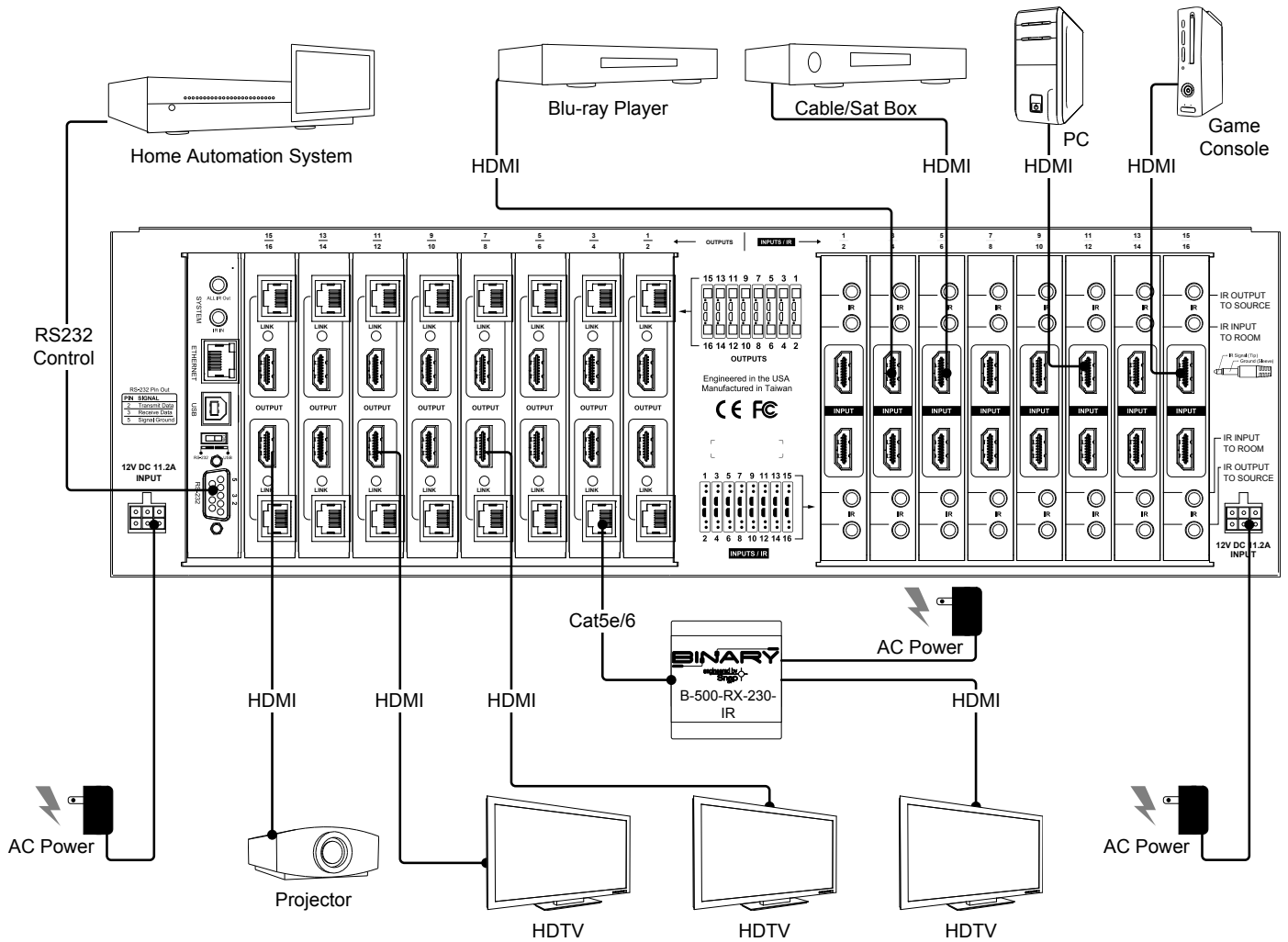



## 7.2. Basic Instructions

These are the basic steps that must be taken to connect equipment to the inputs and outputs of the matrix switcher and configure the system for use. See the sections listed for full information on completing each step.

1. Unpack the matrix and install it near the source equipment. (7.4. Switcher Location and Placement, page 10)  
**Note: Do not provide power to the matrix switcher until step 8.**
2. Install and connect each source to an input on the matrix switcher using the shortest HDMI cable possible. (7.5. HDMI Input Connections, page 11)
3. Install the displays and wiring. Use HDMI cables or Cat5e/6 and B-500-RX-230-IR HDBaseT Receivers to connect each display to the matrix outputs. (7.6. Output Connections, page 11)
4. Record the inputs and outputs used in the System Layout Chart for future reference. (14. System Layout Chart, page 28)
5. If a control system is being used, connect it to the matrix switcher and configure for the driver type being used: IR, RS232, or IP control. (7.7. Matrix Control Connections, page 13)
6. Install and configure the driver for matrix switching control into the control system processor. (7.7. Matrix Control Connections, page 13)
7. Install the IR equipment. (7.8. IR Pass-Through Installation and Setup, page 14)
8. Attach the power supplies to the matrix, sources, and displays, then power up the system.
9. Test all input and output selections for sync, reliable switching, correct audio format and video resolution. Use the factory remote or the Matrix Configuration Utility to set up the input EDIDs. (8. EDID Configuration, page 18)
10. Change any advanced settings in the Matrix Configuration Utility as needed to suit the installation. (9. Advanced Setup Using the Configuration Utility, page 22)

## 7.3. Installation Tips

Following these tips during the installation process will help guarantee a successful installation.

- **Test every cable before use.**  
Always test cables before use. Field-terminated cables should be checked for continuity after termination to be sure the connectors were installed correctly.
- **Label each cable as it is installed.**  
This will aid in connection setup and programming, and will also make it easier to come back to a job at a later date and immediately know what is connected where.
- **Complete the System Layout Chart (page 28) in the back of the manual during installation.**  
Record the source connected to each input, the output number of each display, and the method of routing signal in the chart for reference during installation and setup. Use it afterward to keep track of equipment in use, open ports for expansion, and to help identify where to troubleshoot issues if they arise later.
- **Leave an RS232 connection easily accessible for using the Configuration Utility.**  
The B-500-MTRX-230 is equipped with many setup functions that must be accessed by using a PC and the Configuration Utility. Leave an RS232 cable connected during setup and testing that can be connected to the PC with ease. If the matrix is being controlled by RS232, disconnect the control system while using the Utility.
- **Do not fully secure wiring and equipment until setup and testing has been successfully completed.**  
Wait until all programming, sources, and zones have been set up and thoroughly tested to strap wiring and equipment down, in order to avoid restricting access to connections and settings on the equipment.
- **Complete initial setup with all sources connected to the matrix locally.**  
If a source will be connected to an input by an HDMI extender, complete initial setup by connecting directly to the input with a short HDMI cable. Relocate the source and install the extender after the source has been set up and tested, and then confirm the new arrangement works.

## 7.4. Switcher Location and Placement

Binary matrix switchers are designed to deliver unsurpassed technology with superior performance. However, where you install the switcher can have a large effect on the performance that you receive, and the life of the unit. Here are some guidelines to follow when installing a B-500-MTRX-230 Switcher.

- Be sure that the unit is in a well-ventilated area that provides adequate cooling.
- Do not block the cooling vents located on both sides of the unit.
- Do not place the unit on carpeting or any similar material.
- Do not install the unit near a source of heat, or in an extremely humid or wet location.
- If your installation lacks good air flow (such as solid cabinet doors or wall-mounted racks), it may be necessary to create ventilation to allow outside air into the space.
- Allow a minimum of 3" of free air space on either side of the unit. (Does not apply to rack mounting)
- Allow a minimum of 2" of depth behind unit to accommodate cables and connectors.
- When placing on a cabinet shelf, position the unit with all feet resting on a solid level surface.

### 7.4.1. Rack Installation

The B-500-MTRX-230-8X16/16X16 can be mounted in a rack with the front or rear panel facing outward, and will displace 3U of vertical space when installed. Rear-facing installation allows for easy access to the connections for installations that do not require the front panel of the unit to be accessed. Front-facing mounting is useful for applications where the front panel must be accessible or visible.

The rack ears are packaged separately from the matrix switcher in the box. Attach the ears to the sides of the matrix at the front or back using the included screws. Tighten them with a #2 Phillips Screwdriver. It may be necessary to remove the feet from the bottom when rack mounting the matrix switcher. Remove the screws for the feet with a #2 Phillips Screwdriver, and store the feet and screws together in case they are needed in the future.

**Note:** *The rack ears and mounting holes are only designed to safely hold the weight of the B-500-MTRX-230. Do not use the matrix switcher as a shelf for other equipment in the rack.*

## 7.5. HDMI Input Connections

Each of the 8 or 16 inputs on the B-500-MTRX-230-8X16/16X16 utilizes a standard HDMI port for connection. Follow these guidelines when connecting sources to the inputs.

- Always use the shortest cable possible between source equipment and the matrix switcher inputs. Use high speed rated cables to guarantee the best possible performance.
- Avoid using HDMI cable adapters in runs. Always run one unbroken cable when possible.

## 7.6. Output Connections

The B-500-MTRX-230 matrix switcher is equipped with one HDMI and one HDBaseT output port for each of the 16 output zones. See the sections below for specific instructions and details for each connection type.

**Note:** Any input selected on an output zone is played on both the HDMI and HDBaseT outputs for that zone simultaneously. This can be used to feed the same source to two devices. Read more about this feature below.

### 7.6.1. Choosing the Correct Output

Outputs to displays can be connected using an HDMI cable or a Cat5e/6 cable and HDBaseT Receiver (with a short HDMI cable connecting the Receiver to the display). For any run over about 50 feet, or for any output that will utilize IR pass-through, use HDBaseT.

For short runs where HDMI cables can be routed to the display and/or no IR pass-through is needed, or if there is HDMI equipment connected between the matrix output and the display (like an AV receiver), it may be best to use the HDMI output to connect equipment.

In some situations it may be beneficial to use both outputs. If two displays need to be fed the same source at all times, one display can be fed from the HDBaseT output, and one from the HDMI output. In jobs with an AV receiver feeding surround sound to a zone, the audio can be fed to the receiver via HDMI, and an HDBaseT receiver can be used to route video to the display. This is beneficial with AV receivers that have older or less reliable HDMI scaling or pass-through.

### 7.6.2. HDMI Outputs

To use an HDMI output to feed a display, connect between the output of the matrix switcher and the input of the display. Follow the guidelines below when using HDMI outputs for the best performance and reliability.

- Always use the shortest cable possible between equipment. Use high speed rated cables to guarantee the best possible performance.
- Avoid using HDMI cable adapters in runs. Always run one unbroken HDMI cable.
- When routing HDMI to an AV receiver for surround sound, then out of the receiver to a display, make sure to set the AV receiver to an HDMI mode where the signal will not be processed or scaled to a different format. This will avoid signal timing issues that can cause intermittent sync or total loss of sync. Contact the device manufacturer for details regarding HDMI setup.

### 7.6.3. HDBaseT Outputs

Follow these guidelines when selecting and installing the HDBaseT cable, and then follow the instructions afterward to complete the connections for an output.

#### 7.6.3.1. HDBaseT Wiring Recommendations

##### Cable Type- Shielded or Unshielded Cat5e/6

- Cable Distance Limitations:  
**Cat5e/Cat6:** Up to 200 ft  
**Cat6a:** Up to 230 ft
- Use at least Category 5e high-quality twisted pair solid conductor cable rated to no less than 350 MHz bandwidth. The higher the cable standard, the better it will perform.
- For the best results install a shielded cable. This will prevent signal dropout and artifacts from being caused by electromagnetic and radio interference (EMI/RFI) from ceiling fans, appliances and electric motors.
- Use no more than two 5 meter or shorter, solid or stranded, 568B terminated patch cables in the run. Use shielded patch cables if the run is shielded to maintain shield continuity.
- Use no more than two keystones or couplers in the run. Use shielded keystones or couplers with shielded cable to maintain continuity.
- Cleanly terminate all cable ends and test every cable used before connecting the extender to avoid troubleshooting termination problems later.
- Mark each end of the HDBaseT cable with the included labels to avoid confusion later.

##### Connector Type- RJ45

- Use a high quality RJ45 connector that matches or exceeds the standard of the cable in use. Shielded connectors must be used with shielded cables, and must maintain continuity of the shield to both connectors to protect from interference.
- We highly discourage the use of “EZ” style, open end RJ45’s with HDMI extenders.
- Always terminate RJ45 connectors in the HDBaseT signal path to the 568B termination standard as required by HDBaseT standards.

##### TIA/EIA Standard 568-B (Gold Pins Facing Up)

Pin 1	White/Orange	Pin 5	White/Blue
Pin 2	Orange	Pin 6	Green
Pin 3	White/Green	Pin 7	White/Brown
Pin 4	Blue	Pin 8	Brown



#### 7.6.3.2. Installation Instructions

1. Install the Cat5e/6 cable and terminate the ends. Then test the cable to ensure operation.
2. Connect the HDBaseT cable to the desired HDBaseT output of the matrix switcher.
3. Connect the HDBaseT cable to the B-500-RX-230-IR Receiver or the HDBaseT device in use.
4. Connect an HDMI cable (2 meters or shorter is recommended) between the HDMI OUT port on the Receiver and the desired HDMI input on the Display.
5. Attach the power supply to the Receiver and power the unit.
6. Installation is complete. Test all connected inputs and outputs together to ensure reliable operation.
7. For IR Pass-Through Integration, see section 7.8. IR Pass-Through Installation and Setup, page 14.

## 7.7. Matrix Control Connections

All drivers, associated software and extra documentation are available on the B-500-MTRX-230 product page at [www.SnapAV.com](http://www.SnapAV.com) under the Support Tab.

### 7.7.1. IR Control

The B-500-MTRX-230 can be controlled by IR flasher from the front panel receiver or by attaching a mono cable from the control system flasher output to the “System IR In” port on the back of the matrix switcher. For the most reliable control, use the System IR In port.

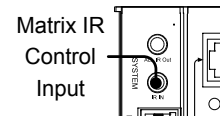

The matrix switcher can also be controlled by commands received on IR Receiver inputs from connected B-500-RX-230-IR HDBaseT Receivers. (See Section 7.10.2. IR Pass-Through from Rooms to Sources on page 17 for an application example of this feature.)

**Note:** System IR control, front panel IR Receiver and Matrix control from Room can be disabled when not in use by using the Configuration Utility. See the Configuration Utility manual section, “Other Settings” for more information.

### 7.7.2. RS232 Control

To control the B-500-MTRX-230 with RS232, the devices must use the correct pin configuration for the control system in use.

The matrix switcher receives control data on pin 2 (RxD – Data Receive) and transmits control data on pin 3 (TxD - Data Transmit). The connection cable between the matrix switcher and the Automation System will need to be configured so that pin 2 (RxD) on the switcher is connected to the control system TxD pin, and pin 3 (TxD) on the switcher is connected to the control system RxD (Receive Data) pin. See the diagram below for details.

Configuration for control system serial ports can vary. Refer to the documentation for the system in use to ensure proper connection and configuration.

**Note:** This port is also used to communicate with a PC when using the PC Configuration Utility. Refer to the Configuration Utility manual for details.

#### B-500-MTRX-230 RS232 Port Configuration

Pin	Function
2	RxD (Data Receive)
3	TxD (Data Transmit)
5	Ground/Common

#### DB9 Female Connector

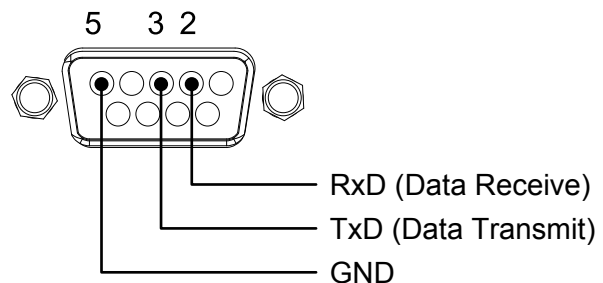

### 7.7.3. Ethernet/IP Control

The B-500-MTRX-230 includes an Ethernet port that can be used to control the device using Telnet Protocol. This port follows TIA 568 A/B standards; please refer to these standards when terminating cables.

To configure the matrix switcher for use with the driver, it will be necessary to connect the unit to a PC and access it with the Matrix Configuration Utility. See the Configuration Utility manual and the IP driver documentation for complete setup instructions.

## 7.8. IR Pass-Through Installation and Setup

To utilize IR pass-through between a display location and the matrix switcher, install a B-500-RX-230-IR at the display and use HDBaseT for routing the signal. The matrix switcher and the matrix receiver are equipped with ports to allow commands to be sent to the display or from the display area. This section details the pinouts and correct use of the IR pass-through ports.

### 7.8.1. Matrix Switcher IR Connections

The ports indicated in the diagram are described in detail below. Guides for standard applications are included on the following pages for reference during setup.

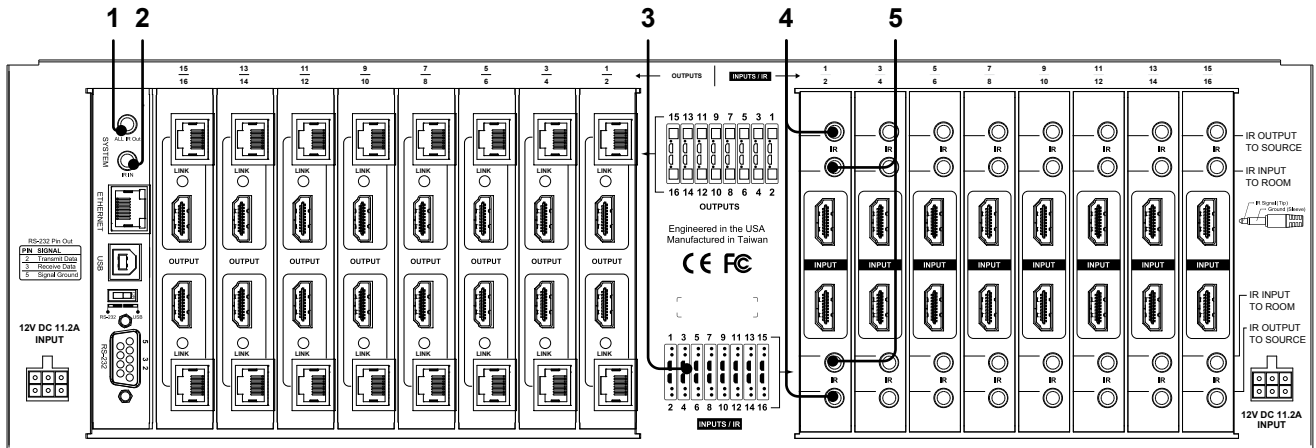

#### 1. System All IR Out

This port repeats any command sent from the IR Receiver ports on B-500-RX-230-IR Matrix Receivers connected to any HDBaseT output.

#### 2. System IR In

3.5mm mono mini IR input port for matrix switcher IR control.

#### 3. System Input Legend

Printed diagram to indicate input and IR connection numbering.

#### 4. IR Output to Source 1 through 16

The IR output from each connected B-500-RX-230-IR is transmitted to the IR OUTPUT TO SOURCE ports. Commands can be routed to the source selected or to the like-numbered port.

#### 5. IR Input to Room 1 through 16

Use 3.5mm mini-mono cables to connect IR flasher outputs on a control system to these ports to send commands to displays or equipment located at the B-500-RX-230-IR matrix receiver location. The number corresponds to the output zone number, so IR Input to Room port 1 will send signals to HDBaseT output 1.

### 7.8.2. Matrix Switcher IR Port Configuration

All IR connection ports on the B-500-MTRX-230 are 3.5mm mono mini and use this pinout configuration. Consult with the manufacturer of any attached IR equipment to confirm their pinout matches before use.

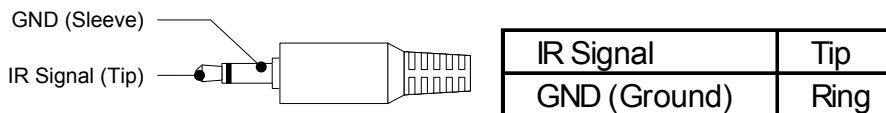

### 7.9. B-500-RX-230-IR IR Connections

The B-500-RX-230-IR IR ports are described below. Use the diagram for reference.

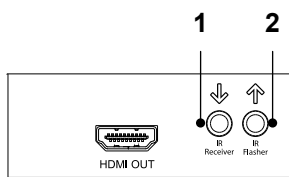

#### 7.9.1. IR Receiver

Attach an IR receiver to this port to capture IR commands in the room for pass through to sources. This port will also send commands back to the matrix switcher for control of source selection in each zone.

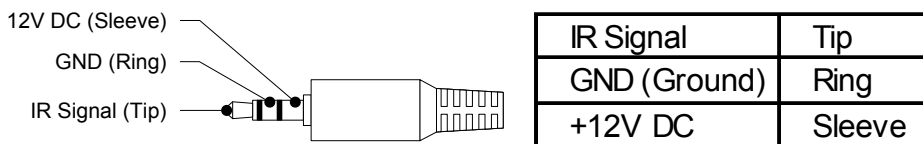

#### 7.9.2. IR Flasher

Attach an IR flasher to this port for controlling a display or other equipment with commands sent from a control system flasher output, into the matrix switcher IR INPUT TO ROOM ports and then to this port.

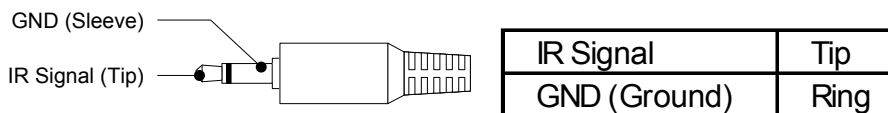

#### 7.9.3. Yellow Tag IR Adapter

The yellow tagged adapter included with the B-500-RX-230-IR (illustrated below) is used to plug a 3.5mm mono mini cable into the IR Receiver port of the B-500-RX-230-IR. This is used to send IR commands to the matrix switcher from other flasher outputs instead of an IR Receiver.

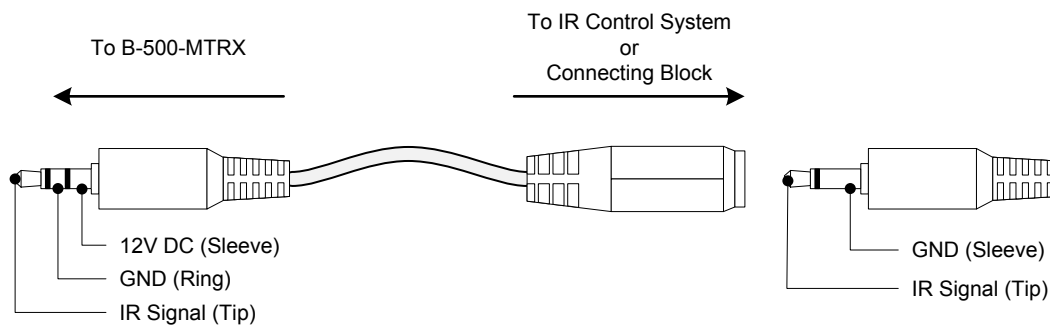

## 7.10. IR Application Diagrams

### 7.10.1. IR Pass-Through from Control System

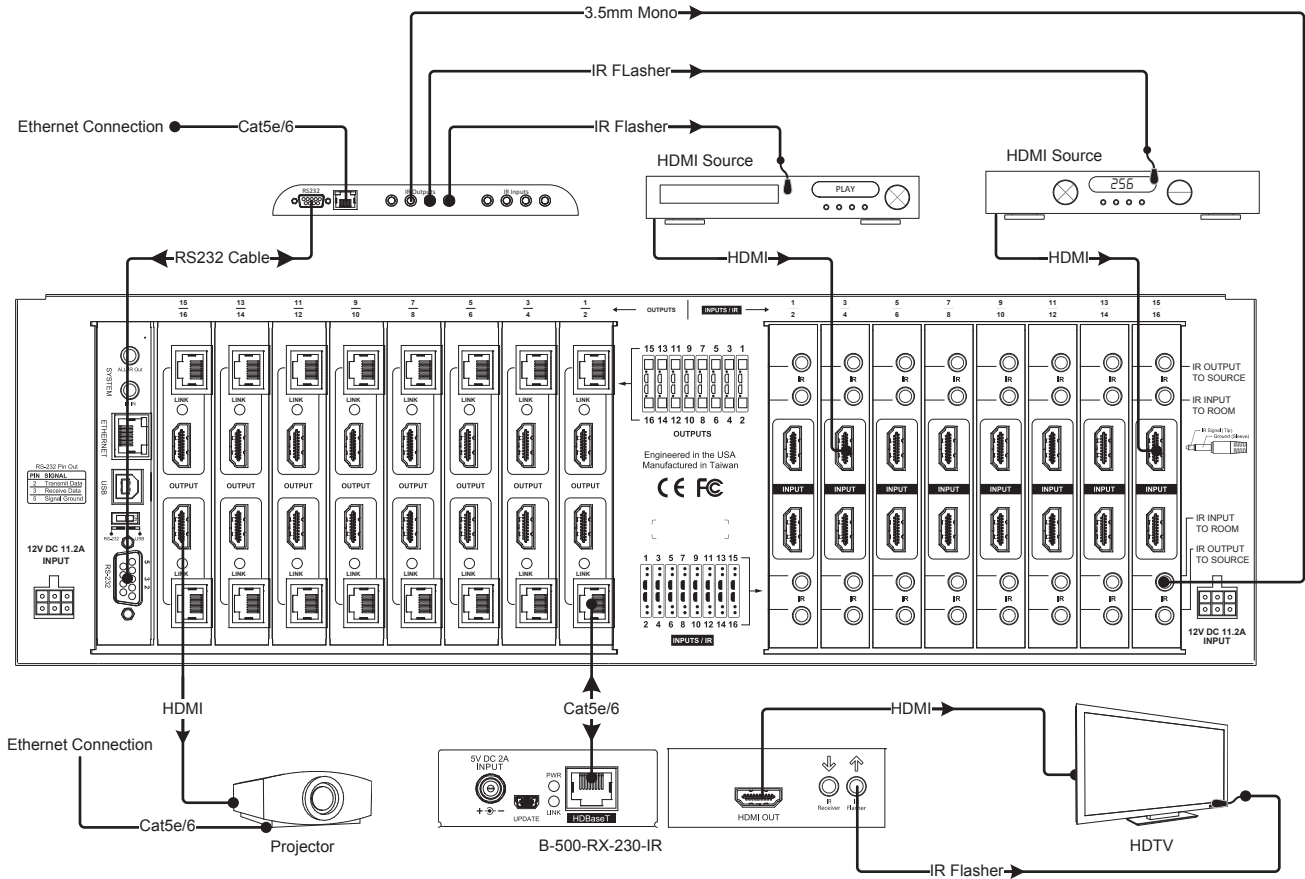

The diagram above illustrates a typical installation with a B-500-MTRX-230 where all of the equipment is being controlled by a control system that uses RF (Radio Frequency) remotes in each output zone.

- The RF remotes transmit commands back to the control system which then sends commands to each device being controlled. Custom programming by the installer sets the control system up to automatically switch inputs and outputs in the matrix switcher as needed, so the end user only has to select the source they want to watch.
- Each display (only one is pictured for reference) requiring IR control is connected to the system via the HDBaseT output of the matrix switcher. Cat5e/6 cable connects to a B-500-RX-230-IR Receiver, which is attached to the display via HDMI for signal. An IR flasher connected to the IR flasher port sends the IR commands to the display. Sources are directly controlled by the control system.
- IR control for displays is routed from the control system to the matrix switcher using 3.5mm mono mini cables plugged into IR INPUT TO ROOM ports. The commands pass from a matrix switcher port to the HDBaseT output of the same number. In the diagram the mono cable used to send commands to the output 16 zone is plugged into IR INPUT TO ROOM port 16. This allows discrete control of each display connected, even if they are models with the same codes.
- Some displays and projectors can be controlled by other methods than IR. The projector pictured features IP control, so it is receiving commands from the control system over an Ethernet connection. An HDMI cable is connecting it to the matrix switcher output since it is installed close enough to the equipment and requires no IR flasher.
- When the system is in use, if two outputs are connected to the same input, the source will change on both outputs with any command sent since it can't send two HDMI streams at once. This must be considered when deciding on the sources to connect for distribution.

**Example:** In a home with five displays connected, if users in every room want to watch satellite on different channels, there must be five satellite receivers set up as sources. With custom programming, each output can be programmed to use only one of the satellite source inputs, giving each output a dedicated satellite box, while allowing other less-used sources to connect to any output.



## 7.10.2. IR Pass-Through from Rooms to Sources

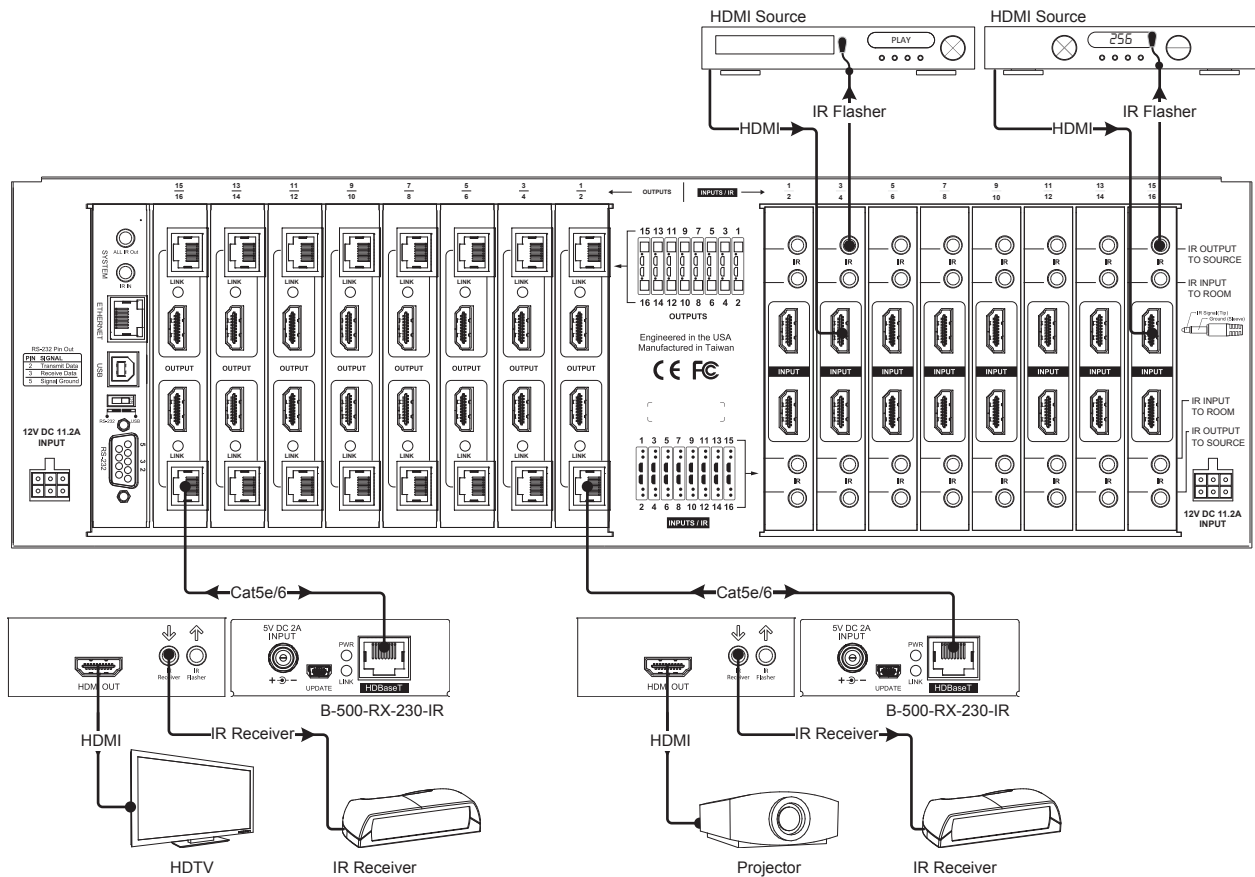

The diagram above illustrates a typical installation with a B-500-MTRX-230 where all of the equipment is being controlled by IR remotes in each output zone.

- In each room with a connected display, an entry-level universal IR remote is being used to control the display and sources in use. Custom programming set up in each remote by the installer sends IR commands out of the remote meant for the display device in the room, the sources, and the matrix switcher simultaneously. The matrix commands are programmed to be sent automatically as needed so the end user only has to select the source they want to watch.
- To make this system work seamlessly, two advanced IR options have been enabled in the matrix switcher Configuration Utility “Other Settings” menu: IR Source Routing and IR Matrix Control from room.
  - IR Source Routing allows the commands from the room to be routed directly to the source selected to be displayed in the room. This simplifies IR routing because only one flasher has to connect to the source.
  - IR Matrix Control sets the matrix switcher so that any command sent from any HDBaseT output to control the matrix is automatically received internally, eliminating the need for an external connection back to the matrix for control. See Section 9. Advanced Setup Using the Configuration Utility on page 22 for more information on changing these settings.
- When the commands are sent, the display device is controlled directly by the remote. The commands for the matrix switcher and sources are picked up by the IR receiver connected to the B-500-RX-230-IR and sent back to the correct IR OUTPUT TO SOURCE port and to the matrix.
- When the system is in use, if two outputs are connected to the same input, the source will change on both outputs with any command sent since it can't send two HDMI streams at once. This must be considered when deciding on the sources to connect for distribution.

**Example:** In a home with five displays connected, if users in every room want to watch satellite on different channels, there must be five satellite receivers set up as sources. With custom programming, each output can be programmed to use only one of the satellite source inputs, giving each output a dedicated satellite box while allowing other less-used sources to connect to any output.

## 8. EDID Configuration

The displays used within an installation usually vary from room to room, and some may not support all resolutions available from a source. It is necessary to make sure sources will provide a video and audio format compatible with all connected displays programmed to use them. To accomplish this, the B-500-MTRX-230 includes built-in EDID management for each source input. The stored EDID is per source, so all display locations will see the same resolution and have the same audio format when that source is selected.

**Note:** Source is only able to output one video resolution and one audio format.

**Note:** The default EDID for each input is always 1080p with 2 channel stereo audio, since this format is accepted by most displays with no issues.

The following sections explain configuring EDIDs via the included IR Remote. Before configuring the EDID, be sure to refer to the source and display manuals for available features and resolutions for each device. For more information about using the included remote, see Section 11.1 IR Remote on page 23.

While all EDID configurations are available via the remote, the Configuration Utility can be used for faster setup. Download the Configuration Utility and manual on the Support Tab at the product page for the B-500-MTRX-230 at [www.SnapAV.com](http://www.SnapAV.com).

**What is EDID?** EDID, or Extended Display Identification Data, is a stream of information sent from a display to a source when the two devices are connected to tell the source what video and audio formats the display can use. This prevents sources from outputting media that won't work with the display.

**See Section 11.1. IR Remote on page 23 for instructions on using the included IR remote for setup.**

### 8.1. Source Setup

Check each source and confirm that the audio format and video resolution are set so that they will change based on the EDID. Normally this setting is called "Auto" or similar.

**Note:** EDID setup is not required if the source supports setting one fixed video resolution and audio format.

### 8.2. Display Setup

It is recommended that Consumer Electronics Control (CEC) be turned OFF in all displays when using the B-500-MTRX-230. This will provide for proper communication of video/audio signals and allow EDIDs to function at their optimum performance. Refer to the display's manual for information on how to turn this function OFF.

### 8.3. Auto EDID Configuration

The quickest and easiest method for configuration is to use Auto EDID. When this mode is used the matrix switcher looks at the EDID from each of the connected displays. It uses the highest common video resolution to create a new EDID and saves that EDID in all of the inputs.

**Note:** Auto EDID sets audio to 2ch stereo for all inputs regardless of the capability of the connected displays. If multi-channel audio is desired, embedded EDIDs or Learned EDIDs will need to be used.

#### When to use Auto EDID

- All sources will be available on all displays.
- As a first step to configuration following up with advanced methods for particular displays and dedicated sources.

#### 8.3.1. How to Configure Auto EDID

To set up Auto EDID configuration, first make sure that all displays are powered on and connected to the matrix switcher. Then, press the following remote buttons in this order. Be sure to press each button within 10 seconds of the previous button-press to prevent the command from resetting.

Set EDID Based on All Connected Displays	Display Readout (Example)
1. Press DEFAULT	Ed --
2. Press Number Key 9	AA A.11
3. Press ENTER	AA A.Q.

## 8.4. Embedded EDID Configuration

In addition to the automatic configuration method, EDIDs in the B-500-MTRX-230 can be set to inputs manually by selecting an EDID from the embedded list (default EDIDs programmed into the matrix switcher).

The matrix switcher contains eight 'embedded' EDIDs that may be assigned to inputs. These EDIDs define groups of video and audio capabilities that are useful for configuring sources in most systems.

### 8.4.1. Embedded EDID Chart

Embedded EDID	Resolution	Color Depth	Audio
1	1080p@60Hz	24-Bit	7.1ch
2 (Factory Default)	1080p@60Hz	24-Bit	2ch
3	1080p@60Hz	24-Bit 3D	7.1ch
4	1080p@60Hz	24-Bit 3D	2ch
5	1080p@60Hz	36-Bit 3D	7.1ch
6	1080p@60Hz	36-Bit 3D	2ch
7	1080i@30Hz / 720p@60Hz	24-Bit	7.1ch
8	1080i@30Hz/ 720p@60Hz	24-Bit	2ch

### Explanation of Embedded EDIDs

**Video Resolution** in the Embedded EDIDs is the **highest resolution** a connected source will output. That is, if the source is capable of 1080P@60 it will be required by EDIDs 1-6 to provide that resolution. However, if the source is only capable of 1080i it will output 1080i, etc. It is assumed that any display that can accept the specified video resolution can also accept all standard video resolutions less than that specified.

**Color Depth** is the maximum number of bits used to encode color. 24bit color depth is 8bits per color (red, blue, green).

**3D** indicates that the source can output 3D if it is available in the content.

**Audio Format** indicates the maximum number of audio channels, as well as the audio format that the source is allowed to output. For an Embedded EDID with 7.1ch Audio Format, the source device will output the highest audio possible based on the content. For example, if 7.1ch is not available and 5.1ch is available, then the output will be 5.1ch. The same is true if 2ch stereo is the only audio available from the source. Embedded EDIDs with 2ch stereo will limit output to that audio format regardless of what is available in the content.

**Embedded EDIDs 7 and 8** are provided for legacy displays that can only accept resolutions up to a maximum of 1080i / 720p. The 1080i is listed first since almost all older HD displays can accept 1080i but not all can accept 720p. For these two Embedded EDIDs, (7&8) the source will output 1080i. Should 1080i not be available, the source will output 720p.

**Note:** There is a possibility that 720p may not work for a very small number of older displays that may still be in use. It will be necessary to use a Learned EDID from the display to store in the Input EDID of any sources that will be routed to that display if 720p is not supported. See Section 8.5. EDID Learning on page 20 for directions to set a learned EDID.

### When to Use Embedded EDIDs

- 2 channel audio is required for a particular output.
- Lower video resolution is required for a particular output.

### 8.4.2. How to Set Embedded EDID for a Single Input

Example: Input =1 Embedded EDID=4	Display Readout (Example)
1. Press DEFAULT	Ed --
2. Press Number Key (1-8) to select one Embedded EDID	04 A.11
3. Press INPUT	04 A.11
4. Press Number Key/s to select the Input to which the EDID is applied	04 A.0.
5. Press ENTER	-- -- (success) FF FF (fail)

### 8.4.3. How to Set Embedded EDID for All Inputs

Example: Input =1 Embedded EDID=4	Display Readout (Example)
1. Press DEFAULT	Ed --
2. Press ALL to select all Inputs	Ed --
3. Press Number Key (1-8) to select Embedded EDID	04 A.11
4. Press ENTER	-- -- (success) FF FF (fail)

## 8.5. EDID Learning

For more advanced EDID configuration, learning can be used to assign EDIDs directly from displays to one or more inputs. This is useful when the system contains a display that cannot accept the highest resolution available from sources, but all sources need to be available to all displays.

**Note:** EDIDs can be learned from displays connected via the HDBaseT or the HDMI output.

### When to Use Learned EDIDs

- An older display does not work properly with any of the embedded EDIDs.
- When the source is a PC it may be necessary to use a learned EDID.
- Learning EDID to a single input

#### 8.5.1. How to Learn EDID to a Single Input

Example: Input =1 EDID Learned from Output 4	Display Readout (Example)
1. Press LEARN ONCE to read HDMI port, or TWICE for HDBaseT port.	L.. --
2. Press OUTPUT	L.. --
3. Press Number Key/s to select the Output the EDID is learned from. Use 10+ to select Outputs through 10-16	04 A.11
4. Press INPUT	04 A.11
5. Press Number Key/s to select the Input the EDID is applied. Use 10+ to select Outputs through 10-16	04. 0.1
6. Press ENTER	-- -- (success) FF FF (fail)

### 8.5.2. How to Learn EDID to All Input

Example: Input=All EDID Learned from Output 4	Display Readout (Example)
1. Press LEARN	L... --
2. Press OUTPUT	L... --
3. Press Number Key/s to select the Output the EDID i learned from. Use 10+ to select Outputs through 10-16	04 All
4. Press ENTER	-- -- (success) FF FF (fail)

### 8.6. Viewing Input EDID Status

If there is a question about the EDID set for an input, the status of that input's EDID can be reviewed using the included IR remote and watching the matrix switcher front panel display.

Example: View the EDID for Input 3.	Display Readout (Example)	
	EDID 5 Assigned from Embedded EDID Table	EDID Learned from Output 4
1. Press STATUS	-- --	-- --
2. Press INPUT	-- --	-- --
3. Press Number Key/s to select the Output the EDID is learned from. Use 10+ to select Outputs through 10-16	-- 03.	-- 03.
4. Press ENTER	05 01.	04. 03.

## 9. Advanced Setup Using the Configuration Utility

There are several setup options available that can only be modified using the matrix switcher Configuration Utility. These items are defaulted to the most common settings that should work in most installations.

The Configuration Utility and manual are available for download on the Support Tab of the B-500-MTRX-230 product page at [www.SnapAV.com](http://www.SnapAV.com). Download and run the Utility to gain access to these settings connecting to the matrix and clicking "Other Settings."

### 9.1. IR Source Routing

<b>Default Setting:</b>	Yes
-------------------------	-----

The IR Source Routing feature allows discrete control of the source selected from any connected HDBaseT output using an IR receiver plugged into the B-500-RX-230-IR. This setting is only relevant when using in-room IR remotes to control sources connected to the matrix switcher. When set to Yes, the matrix will route commands from the HDBaseT Receiver to the IR Output to Source port that matches the source input number currently selected on that output.

When set to No, commands will be sent only out of the IR Output to Source port that matches the HDBaseT Receiver number from which it originated .

### 9.2. IR Front Panel IR Enable

<b>Default Setting:</b>	Yes
-------------------------	-----

This setting controls the operation of the front panel IR receiver built into the B-500-MTRX-230. This should be disabled if using the SYSTEM IR IN port to control the matrix switcher via IR, or if the matrix switcher is missing or receiving extra commands during use (stray IR interfering with the port).

### 9.3. Matrix Control from Room Enable

<b>Default Setting:</b>	Yes
-------------------------	-----

The Matrix Control from Room Enable option allows Matrix Control IR commands to be sent from the room as if a source were being controlled. Turn this option off if the matrix switcher is being controlled by any other method than in-room IR.

**Note:** To use Matrix Control from Room, it is recommended to program a universal remote control with discrete commands for matrix control to keep in each zone, rather than using the included IR remote or commands learned from it. Go to the Support Tab of the B-500-MTRX-230 product page at [www.SnapAV.com](http://www.SnapAV.com) to see and download the available IR codes and drivers for IR remote programming.

### 9.4. Front Panel Power Button Active

<b>Default Setting:</b>	Yes
-------------------------	-----

The Front Panel Power Button can be disabled if desired. Disable the button when the matrix switcher is programmed to be on at all times or in jobs where turning off the matrix from the switcher can cause issues with control.

## 10. Firmware Update

Binary may occasionally release new firmware for the B-500-MTRX-230 to address new standards and technology. It will never be necessary to perform an update to an existing, correctly functioning system, but during installation or service, it is recommended to check the installed version to be sure it is the newest available.

For full update instructions, see the section titled, "Firmware Update" in the Configuration Utility manual. New firmware, the Configuration Utility, and the Configuration utility manual are available for download on the Support Tab of the B-500-MTRX-230 product page at [www.SnapAV.com](http://www.SnapAV.com).

## 11. Operation and Control

During setup and testing, use the included IR remote to control the matrix switcher. After setup is complete, a control method should have been setup and programmed as described in Section 7.7. Matrix Control Connections for regular operation.

### 11.1. IR Remote

This section describes the correct button-push sequences to perform regular operations with the IR remote.

To enter a number higher than 9 when selecting an input or output, press the “10+” button to enter 10, or press “10+” followed by the desired number for 11-16 (Example: “10+” + “2” = 12).

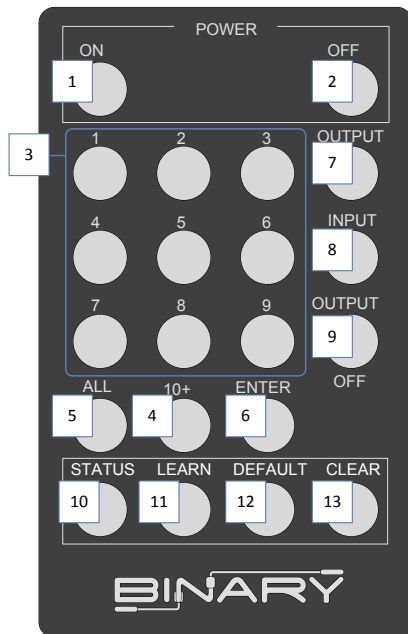

	Key	Function
1	ON	Power on the matrix switcher
2	OFF	Enter standby mode
3	Number Keys 1-9	Select a number
4	10+	Select numbers for Input or Output higher than 9
5	ALL	Select all Inputs or Outputs
6	ENTER*	Enter to trigger the previous setting
7	OUTPUT	Kick off output selection
8	INPUT	Kick off input selection
9	OUTPUT OFF	Turn off/Mute the selected Output
10	STATUS	Present EDID or Output status
11	LEARN	Learn EDID from one output
12	Default	Kick Off Embedded EDID Selection
13	CLEAR*	Clear the former IR operation procedure which user just pressed but has not yet applied by pressing ENTER

#### 11.1.1. Route Inputs to Outputs

Input to Single Output Example: Output=3 Input=4	Display Readout (Example)
1. Press OUTPUT	-- --
2. Press Number Key/s to select the Output the EDID is learned from. Use 10+ to select Outputs through 10-16	03 --
3. Press INPUT	03
4. Press Number Key/s to select the Input. Use 10+ to select Inputs through 10-16	03 04
5. Press ENTER	03 04

<b>Input to All Outputs</b> Example: Output=All Input=4	<b>Display Readout (Example)</b>
1. Press OUTPUT	-- --
2. Press Number Key/s to select the Input. Use 10+ to select Inputs through 10-16	All --
3. Press INPUT	All
4. Press Number Key/s to select Input	All 04
6. Press ENTER	16 04

### 11.1.2. Turn Off (Mute) Outputs

<b>Mute one Output</b> Example: Output=1	<b>Display Readout (Example)</b>
1. Press OUTPUT	-- --
2. Press Number Key/s to select the Output. Use 10+ to select Outputs through 10-16	01 --
3. Press OUTPUT OFF	01 00
4. Press ENTER	01 00

<b>Mute All Outputs</b>	<b>Display Readout (Example)</b>
1. Press OUTPUT	-- --
2. Press ALL to select All Outputs	01 --
3. Press OUTPUT OFF	All 00
4. Press ENTER	16 00

### 11.1.3. Display Output Status

<b>Example: Display the status for Output 3.</b>	<b>Display Readout (Example)</b>	
	<b>Example Output=3, Input=4</b>	<b>Example Output=3 Muted</b>
1. Press STATUS	-- --	-- --
2. Press OUTPUT	-- --	-- ----
3. Press Number Key/s to select the Output. Use 10+ to select Outputs through 10-16	03 --	03 --
4. Press ENTER	03 04	03 00



### 11.1.4. Resetting to Factory Defaults

This procedure resets the B-500-MTRX-230 to factory defaults:

- EDIDs - 1080p 60 2 channel stereo (embedded 2)
- I/O - All Outputs set to Input 1

Reset Factory Defaults	Display Readout (Example)
1. Press DEFAULT	Ed --
2. Press DEFAULT	Ed --
3. Press DEFAULT	Ed --
4. Press DEFAULT	Ed --
5. Press ENTER	0101

**Note:** Resetting factory defaults can take up to 2 minutes to complete. Wait until the screen displays an output and input selection of 1.1 before attempting further setup or use.

## 12. Troubleshooting

If issues arise during installation or testing of the B-500-MTRX-230, follow these guidelines to troubleshoot. Use the System Layout chart on the next page to record a description of each part of the system. If a problem cannot be solved using the methods listed here, fill out the System Layout Chart as completely as possible and contact Binary Tech Support for assistance at (866)838-5052.

### 12.1. General Troubleshooting Guidelines

- Always set up the connections between the matrix switcher and all equipment before attempting EDID setup or testing video and audio to be sure that all displays have been accounted for.
- Only change one part of a setup at a time when troubleshooting. Changing more than one variable may lead to inconsistent results.
- When any issue arises with video or audio, inspect the cable connections first. Most issues arise from a connector not being fully seated in its port or a poorly terminated Cat5e/6 cable.
- Try to simplify the signal route when troubleshooting. Remove any additional equipment from between the source and display as possible, and add one piece back until the issue re-appears.
- If a source will not work with all displays, or a display will only work with some sources, the issue is usually either an incorrect EDID for an input, or a source menu is set incorrectly.
- Swap devices to different ports on the matrix to determine whether issues follow the devices or the ports in use. Issues following sources are almost always related to the internal settings of the source. Set the source output to adjust automatically for the EDID of the display. Then set up the EDIDs using a learned EDID from an output with a “problem” display, or selecting an embedded EDID compatible with all of the connected displays’ supported resolutions.

### 12.2. No Signal from Source to any Display

If a source will not send a signal to any connected display, it is probably due to an issue with the cable in use, the EDID setting for the input, or the settings in the source:

- Swap the cable between the source and the input of the matrix for a short, working HDMI cable.
- Test the source using a different input. If the source works with displays when connected to a different input, the EDID needs to be changed to one that is compatible with all displays.
- If the problem follows the source, its output settings are not compatible with the displays in use, or the source is not working correctly. Test the source and set it up to work by connecting directly to a display with an HDMI cable.

### 12.3. No Signal from any Source to any Display

If a display connected to a matrix output will not sync to any source, the issue is usually either an incompatible EDID on all inputs or a problem with the cable connecting the display to the matrix switcher:

- Learn the EDID of the “problem” output to all inputs.
- Re-terminate the HDBaseT cable (if applicable) and test it for continuity, and try a different HDBaseT receiver. Replace any HDMI cables with known working units.
- Bypass all other equipment and wire directly from the output of the matrix to the input of the display with the shortest HDMI cable possible to eliminate other equipment as the cause of the issue.
- Connect the display wiring to a different matrix switcher output.
- Connect each source directly to the display using an HDMI cable and test to be sure the display and its input port work correctly with sources. If this works there may HDBaseT or HDMI wiring issues.
- Use a known good HDBaseT receiver and a test run of Cat5e/6 cable outside the wall to help identify HDBaseT issues. If the B-500-RX-230-IR HDBaseT Receiver is being used, see its manual for more troubleshooting tips directly related to HDBaseT.

## 12.4. Audio Issues

If a display on an output using 2 channel stereo audio is switched to an input with its EDID set to surround sound audio format, audio at the display speakers may be garbled, missing pieces of the audio track, or muted altogether. This symptom indicates that the display cannot down-convert the audio stream from the source. To fix this issue, the source must be set to output only 2 channel stereo audio.

This may result in limited audio quality in zones with surround systems. With sources like cable or satellite boxes, surround sound audio isn't as critical to the end user experience, so these sources can send stereo audio through the speaker system with no perceived difference. For Blu-ray players or streaming devices where sound quality is critical, the compromise would be to connect a second source of the same type so that one is set to stereo and one is set to surround sound, or one is connected directly to the AV receiver instead of the matrix switch.

## 13. Contacting Tech Support

Phone: (866) 838-5052

Email: [Techsupport@SnapAV.com](mailto:Techsupport@SnapAV.com)

## 14. System Layout Chart

Use this chart to identify the sources and displays attached to the system, and make any notes about each part. When completing the outputs chart, make sure to indicate whether an HDMI cable, B-500-RX-230-IR, or another brand HDBaseT receiver is being used to extend signal to the display, and indicate the approximate length of any cables.

<b>Input Number</b>	<b>Source Brand and Model</b>	<b>Location</b>	<b>Cable Length</b>	<b>Notes</b>
1				
2				
3				
4				
5				
6				
7				
8				
9				
10				
11				
12				
13				
14				
15				
16				

<b>Output Number</b>	<b>Source Brand and Model</b>	<b>Location</b>	<b>HDMI or HDBaseT</b>	<b>Cable Length</b>	<b>Notes</b>
1					
2					
3					
4					
5					
6					
7					
8					
9					
10					
11					
12					
13					
14					
15					
16					

## 15. Specifications

TECHNICAL			
	B-500-MTRX-230-8X16	B-500-MTRX-230-16X16	
HDMI Compliance	HDMI 3D		
HDCP Compliance	Yes		
Video Bandwidth	6.75Gbps		
HDMI over UTP Transmission	Resolution	Cat5e/ Cat6	Cat6a
	1080i / 720p 24-bit color	200ft	230ft
	Full HD 1080P 24-bit color	200ft	230ft
	Full HD 1080P 36-bit deep color	200ft	230ft
Input TMDS Signal	1.2 Volts (peak-to-peak)		
Input DDC Signal	5 Volts (peak-to-peak, TTL)		
ESD Protection	(1) Human body model — $\pm 15\text{kV}$ (air-gap discharge) & $\pm 8\text{kV}$ (contact discharge) (2) Core chipset — $\pm 8\text{kV}$		
IR Signal (Bi-directional)	Carrier frequency: 20-60kHz		
CONNECTIONS			
HDBaseT Link	16 x RJ45		
HDMI	24 x HDMI Type A (19-pin female)	32 x HDMI Type A (19-pin female)	
IR (In)	1 x 3.5mm Mono		
All IR (Out)	1 x 3.5mm Mono		
IR Input to Room	16 x 3.5mm Mono		
IR Output to Source	16 x 3.5mm Mono		
RS232 Control Port	DB9		
Power	Polarized		
Ethernet	1 x RJ45		
MECHANICAL			
Housing	Metal enclosure		
Dimensions (W x H x D)	17.32" x 5.20" x 12.72" (without ears)		
Weight	21 lbs.		
Power Supply	12V DC 11.25A		
Power Consumption	110w (max)	120w (max)	
Operation Temperature	32~104°F		
Storage Temperature	-4~140°F		
Relative Humidity	20~90% RH (no condensation)		
Certifications and Compliance	Product: CE, FCC Power Supply: CE, FCC, UL		

## 16. Warranty



### 2 Year Limited Warranty

This SnapAV® product has a 2-year Limited Warranty. This warranty includes parts and labor repairs on all components found to be defective in material or workmanship under normal conditions of use. This warranty shall not apply to products which have been abused, modified or disassembled. Products to be repaired under this warranty must be returned to SnapAV or a designated service center with prior notification and an assigned return authorization number (RA).



**BINARY**

engineered by  
**Snap**  
av