

# 20.3" Modero® X Series Panoramic Tabletop Touch Panel no Camera, no Microphone

MXT-2000XL-PAN-NC (FG5968-32)



## Overview

The MXT-2000XL-PAN-NC / 20.3" Modero X® Series Panoramic Tabletop Touch Panel (No Camera, No Microphone) is specifically designed to exclude the camera, Near Field Communication™ (NFC), microphone and Bluetooth functions of the original Modero X Series panel to meet the security requirements of facilities that do not allow these capabilities.

The Modero X Series Touch Panels provide several industry firsts including a beautiful, panoramic capacitive multi-touch screen that provides users access to multiple applications with minimal navigation. The distinctive, low-profile design is engineered to sit perfectly on a table without obstructing views, and comes with a variety of mounting options for added security and convenience.

## Common Applications

The MXT-2000XL-PAN is ideal for federal, state, and local government or military facilities with strict security restrictions due to the storage, use, discussion or electronic processing of sensitive or classified information. The MXT-2000XL-PAN feature modifications to support the added security measures necessary in secure environments such as sensitive compartmented information facilities, emergency operations centers or command headquarters. These modified panels give users robust functionality and capabilities while adhering to essential operational security guidelines.

## Features

- **Panoramic Control Surface** – Combined with the new PanTastic UI, the panoramic touch panels take the user experience to a whole new level with an impressive control surface to perform activities much in the same way you use a computer – multi-tasking with dedicated spaces
- **Graphic Leaps & Bounds** – The Modero X Series includes some striking new intuitive UI functionality including: gesturing, swiping, dynamic reordering and enhanced animation capabilities
- **Perfect From Any Angle** – Includes In-Plane Switching (IPS), the latest technology in popular tablet/mobile devices that delivers the widest viewing angles and the most accurate color reproduction on the market

## Specifications

TOUCH SCREEN DISPLAY	
Display Type	TFT Active Matrix Color LCD with In-plane Switching Technology (IPS)
Display Size (WH)	20.4" x 9.5" (519 mm x 242 mm), 21.3" (541 mm) diagonal
Viewable Area (WH)	18.7" x 7.8" (475 mm x 198 mm ), 20.3" (514 mm) diagonal
Resolution (WH)	1920x800
Aspect Ratio (WH)	12:5
Brightness	250 cd/m2
Contrast Ratio	1000:1
Color Depth	16.7M colors
Illumination	LED
Touch Overlay	Projected capacitive, multi-touch support, 3 simultaneous max
Viewing Angle	Vertical $\pm 89^\circ$ , Horizontal $\pm 89^\circ$

MEMORY	
SDRAM	512 MB
Flash	4 GB
Maximum Project Size	2.4 GB flash available to user

COMMUNICATIONS	
ETHERNET	10/100 port, RJ-45 connector. Supported IP and IP-Based Protocols: UCP, TCP, ICMP, ICSP, IGMP, DHCP, Telnet, FTP, DNS, RFB (for VNC), HTTP
USB	(3) USB host 2.0, Type A ports: Firmware upgrade, touch panel file transfer, JPEG image viewer, HID peripherals, USB audio output for headsets  (1) Micro-USB device port: Disabled

VIDEO	
Supported Video Codecs	MPEG-2-TS: MPEG-2 Main Profile @High Level up to 720p at 25 fps (decode only)  MPEG-2-TS: H.264 High Profile @Layer 4, AAC-LC up to 720p at 25 fps (decode)  MJPEG up to 720p at 25 fps (decode only)
Supported Video Transport Streams	MPEG-TS for MPEG-2 and H.264; HTTP for MJPEG
Max Number of Active Video Streams	One decode

AUDIO	
Speakers	4 ohm, 2 Watt, 300 Hz cutoff frequency
Supported Audio Codecs	MP2 Layer I and II, MP3 (8 kHz, 11.025 kHz, 12 kHz, 16 kHz, 22.05 kHz, 24 kHz, 32 kHz, 44.1 kHz, 48 kHz)  AAC-LC (8 kHz, 96 kHz)  G.711 with $\mu$ Law (decode at 8 kHz)
File Formats	WAV, MP3 (as part of touch panel file only - no USB storage)

GRAPHICS ENGINE	
AMX G4	G4 enhanced feature set supporting multi-touch and gestures, scrolling, transitions - See TPD4 Operations Guide for more information

EMBEDDED APPLICATIONS	
Remote Management	VNC Server, G4 Web Control, AMX Resource Management Suite

FRONT PANEL COMPONENTS	
Light Sensor	Photosensitive light detector for automatic adjustment of the panel brightness
Proximity Detector	Max range = ~3', typ range = ~1', FOV = ~10 degrees
Sleep Button	Sleep button to activate sleep mode and powering off. Also provides access to setup pages (can be disabled)

CONNECTIONS	
Ethernet	10/100 port, RJ-45 connector
USB	(3) USB host 2.0, Type A ports (1) Micro-USB device port: Disabled
Power	2-pin, locking 3.5mm Phoenix connector

ENVIRONMENTAL	
Temperature (Operating)	32° F to 104° F (0° C to 40° C)
Temperature (Storage)	4° F to 140° F (-20° C to 60° C)
Humidity (Operating)	20% to 85% RH
Humidity (Storage)	5% to 85% RH
Power ("Heat") Dissipation	On: 109.2 BTU/hr, Standby: 10.6 BTU/hr

GENERAL	
Dimensions (HWD)	9 3/16" x 20 3/8" x 5 7/8" (235 mm x 519 mm x 150 mm)
Weight	12.2 lbs (5.53 Kg)
Power Consumption	Full-On: 32W, Standby: 3.10 W
Start-Up Inrush Current	4.0 A for 80 $\mu$ sec
External Power Supply Required	Requires one of these AMX power sources (not included): <ul style="list-style-type: none"> <li>• PSR5.4, 12 VDC, 5.4 A Power Supply with 3.5 mm Phoenix Connector with Retention Screws (FG423-48)</li> <li>• MXA-MPL Modero X Series Multi Preview Live (FG5968-10)</li> </ul>

	<ul style="list-style-type: none"> <li>• MXA-MP Modero X Series Multi Preview (FG5968-20)</li> </ul>
Regulatory Compliance	FCC Part 15 Class B CE EN 55022 CE EN 55024 CE EN 60950-1 IEC 60950-1 C-Tick CISPR 22 Class B IC UL 60950-1 RoHS WEEE
Included Accessories	<ul style="list-style-type: none"> <li>• Locking 2-pin Phoenix mate (41-0002-SA)</li> <li>• MXA-USB-C, USB Port Cover Kit, Modero X/S Series Touch Panel (FG5968-18)</li> <li>• HPG-10, 3/4" Mini-Grommet (FG570-01)</li> <li>• MXA-CLK, Modero X/S Series Cleaning Kit (FG5968-16)</li> </ul>
Optional Accessories	<ul style="list-style-type: none"> <li>• MXA-STMK-20, Secure Table Mount Kit, 20.3" Modero X Tabletop (FG5968-64)</li> <li>• MXA-MP, Modero X/S Series Multi Preview (FG5968-20)</li> <li>• MXA-MPL, Modero X/S Series Multi Preview Live (FG5968-10)</li> <li>• PSR5.4, 12 VDC, 5.4 A Power Supply with 3.5 mm Phoenix Connector with Retention Screws (FG423-48)</li> <li>• HPG-10-10K, 3/4" Mini-Grommet, 10-Pack (FG570-01-10K)</li> <li>• MXA-CLK, Modero X/S Series Screen Cleaning Kit (FG5968-16)</li> <li>• MXA-USB-C, USB Port Covers for the Modero X/S Series Touch Panels (FG5968-18)</li> </ul>

For a more detailed pictorial drawing please visit: <http://www.amx.com/products/MXT-2000XL-PAN-NC.asp>

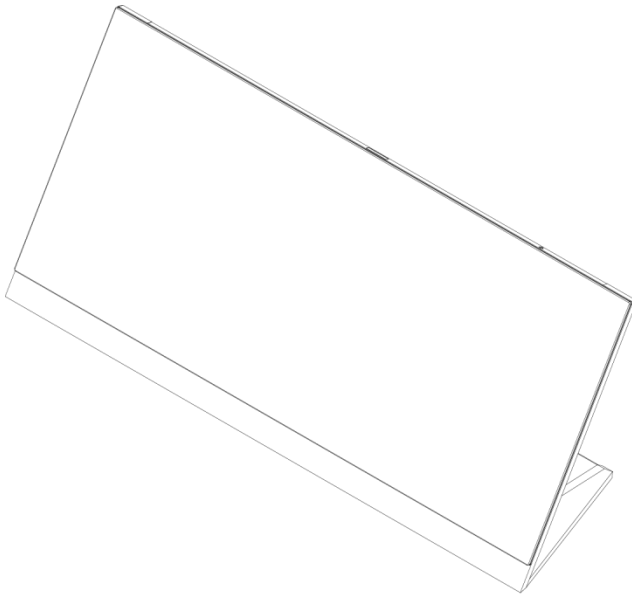

MXT-2000XL-PAN  
(Isometric View)

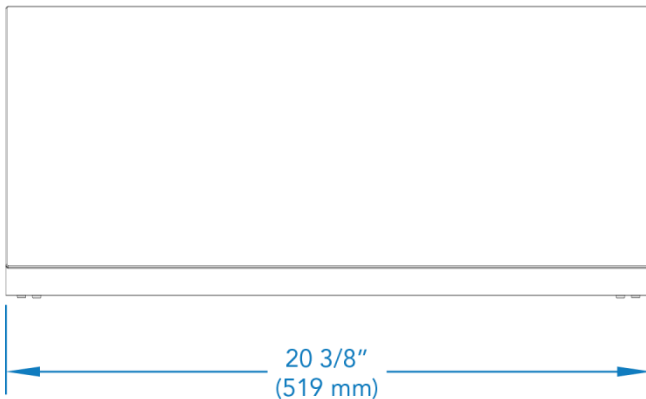

MXT-2000XL-PAN  
(Front View)

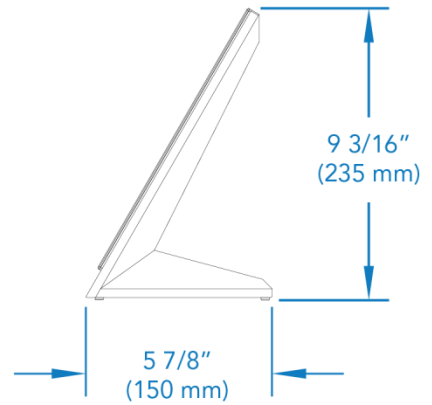

MXT-2000XL-PAN  
(Right View)

**About AMX by HARMAN**

Founded in 1982 and acquired by HARMAN in 2014, AMX® is dedicated to providing AV solutions for an IT World. AMX solves the complexity of managing technology with reliable, consistent and scalable systems comprising control, video switching and distribution, digital signage and technology management. AMX systems are deployed worldwide in conference rooms, classrooms, network operation/command centers, homes, hotels, entertainment venues and broadcast facilities, among others. AMX is part of the HARMAN Professional Group, the only total audio, video, lighting, and control vendor in the professional AV market. HARMAN designs, manufactures and markets premier audio, video, infotainment and integrated control solutions for the automotive, consumer and professional markets. Revised 11.18.16. ©2016 Harman. All rights reserved. Specifications subject to change.

[www.amx.com](http://www.amx.com) | +1.469.624.7400 | 800.222.0193