

# AN-620-SW

## Araknis 620 Switch Quick Start Guide

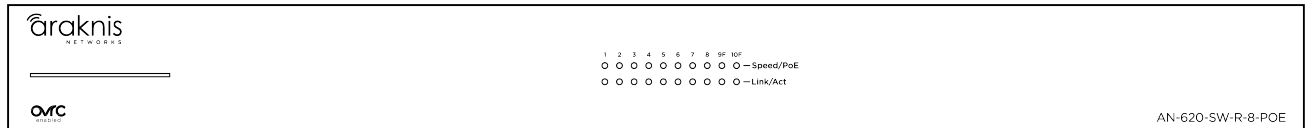

## Welcome to Araknis Networks™

Thank you for choosing an Araknis 620 series managed switch. With multi-gigabit connectivity on all ports, updated modern aesthetics, and a managed interface, the Araknis 620 series switch is a sleek and highly capable addition to any network.

### Series overview

Model	Ethernet Ports	SFP+ Ports	PoE Budget (Watts)
AN-620-SW-R-8-POE	8	2	240
AN-620-SW-R-24-POE	24	2	720

---

# Unboxing

The package contains:

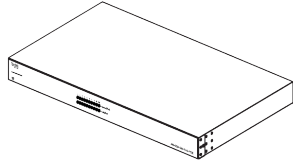

Switch

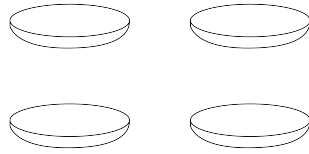

Rubber feet for flat surfaces (4)

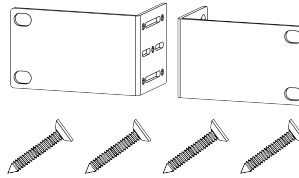

Rack-mount kit:  
ears (2), screws  
(8)



Quick Start Guide  
QR card

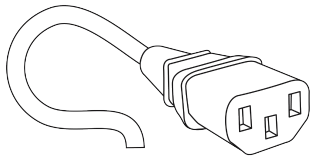

AC power cord

---

# Installing the switch

## Rack mount

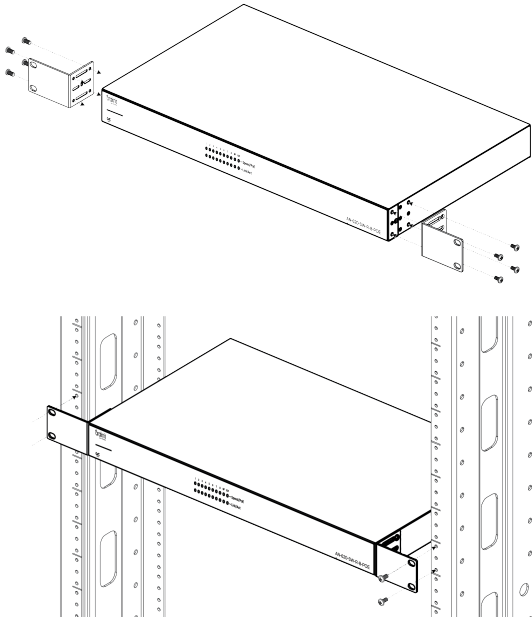

## Shelf mount

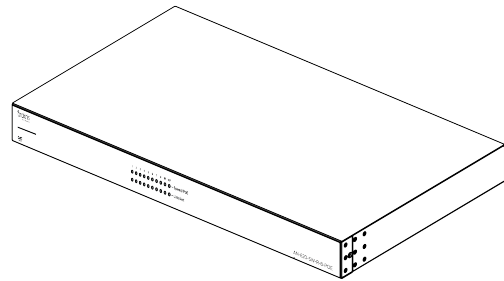

**Caution:** To avoid possible interference or damage, do not stack equipment on top of the switch.

## Rack mounting guidelines

- The maximum ambient temperature of the space the switch is installed in should not exceed 122 °F/50 °C.
- Allow to air flow through the rack.
- Verify all the leveling feet or casters are adjusted correctly and they come in contact with the supporting surface. Always load heavier equipment at the bottom of the rack.
- Make sure the rack is grounded and the equipment is surge protected.

- Do not overload the power equipment, or the switch. Check out our [WattBox Best Practices](#) for more information.

---

# Step 3: Connections

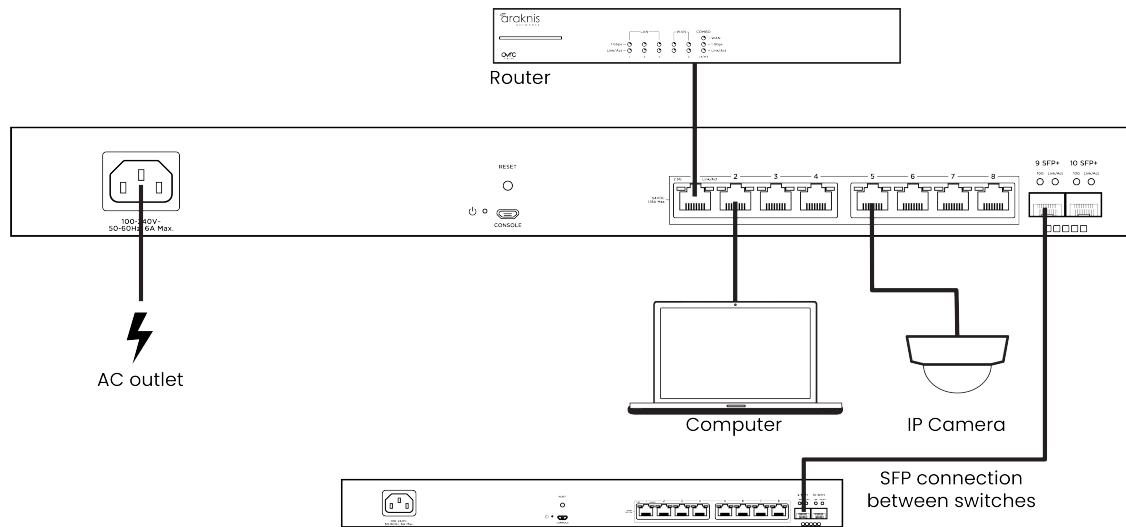

## SFP+ ports

The SFP+ (Small Form Factor Pluggable plus) ports support up to 10 Gbps connection and are typically used to connect switches together. Use SFP+ adapters for RJ45 or multi-mode fiber cables (sold separately).

# PoE budgeting

The PoE budget (Power over Ethernet) limits the amount of power available to all ports, with a maximum of 60W on an individual port. Add the total number of *possible* watts that the connected devices can consume to make sure everything can receive power reliably. See the example below.

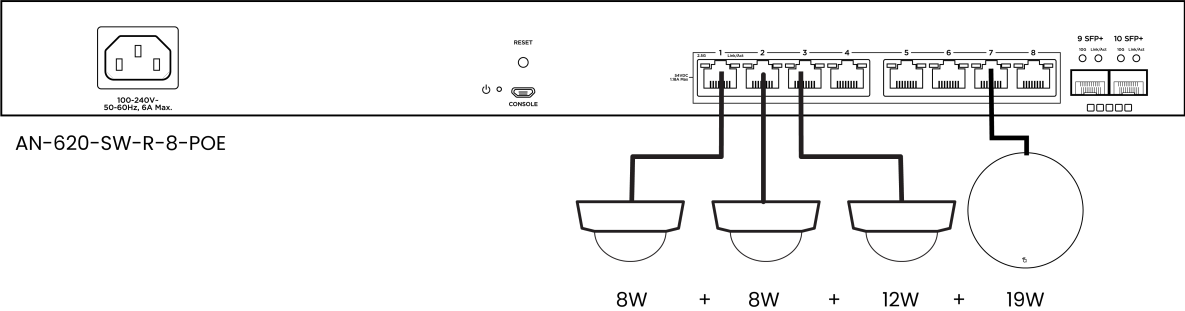

Model	PoE budget (Watts)
AN-620-SW-R-8-POE	240
AN-620-SW-R-24-POE	720

Total PoE budget available = 240  
 Total PoE device consumption = 47  
 Remaining PoE budget available = 193

# LED states & reset procedures

## Front

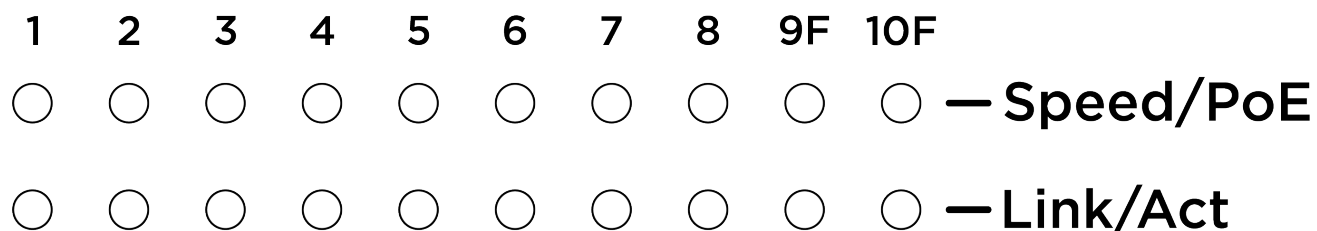

LED	LED state	Description
Power	On	The switch is powered on.
	Off	The switch is powered off.
Speed/PoE	On	The port is passing 2.5Gbps and/or PoE.*
	Off	The port is not passing 2.5Gbps and/or PoE.*
Link/Act	On	The port detects a connection.
	Blinking	Packets are flowing through the port.
	Off	The port does not detect a connection or the port is disabled.

\*Configurable in the web interface.

# Rear

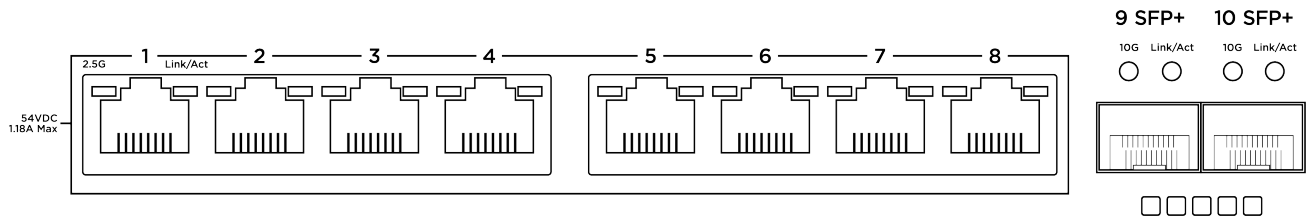

LED	LED state	Description
RJ45 2.5G	On	The RJ45 port is negotiating packets at 2.5Gbps.
	Off	The RJ45 port is not negotiating 2.5Gbps but may be passing traffic. Check the Link/Act LED to verify if packets are flowing through the port.
SFP 10G	On	The SFP port is negotiating packets at 10Gbps.
	Off	The SFP port is not negotiating 10Gbps but may be passing traffic. Check the Link/Act LED to verify if packets are flowing through the port.
Link/Act	Blinking	Packets are flowing through the port.
	Off	The port does not detect a connection.



# Reset procedures

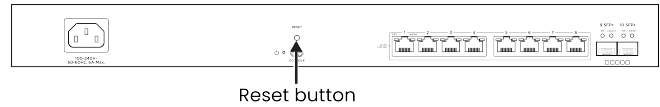

The reset button is on the back of the switch.

**Note:** The front and back power LEDs have the same behavior.

Reset button action	LED state	Description
Hold the reset button for 1-9 seconds	Blinking slowly	Restarts the switch
Hold the reset button for 10-19 seconds	Blinking moderately	Resets the username and password to araknis.
Hold the reset button for more than 20 seconds	Blinking rapidly	Resets the switch to factory defaults.

---

# Step 5: Configuration

Araknis switches can be configured through OvrC or the local interface. The local interface is accessible using OvrC's webconnect feature, typing the switch's DHCP address into your browser's address bar, or using the switch's default IP address.

**Note:** Only features in the local UI are supported by Snap One.

## Configuring the switch in OvrC

OvrC provides remote device management, real-time notifications, and intuitive customer management, using your computer or mobile device. Setup is plug-and-play, with no port forwarding or DDNS address required.

### To add this device to your OvrC account:

1. Connect the switch to the internet.
2. Log into OvrC ([www.ovrc.com](http://www.ovrc.com)).
3. Scan the site using an OvrC Pro device, or add the switch manually by entering the MAC address and Service Tag.

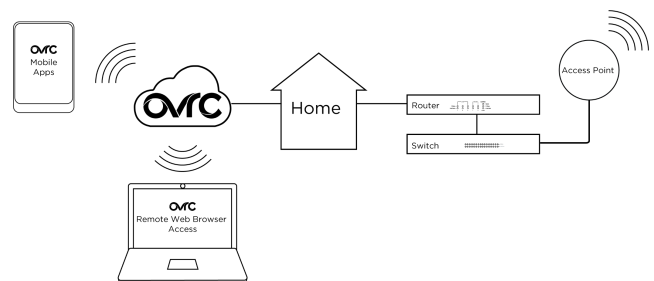

## Logging into the web interface

1. Log into the switch using the default credentials:

<b>Username</b>	araknis
<b>Password</b>	araknis

2. You must update the password after

initial login.

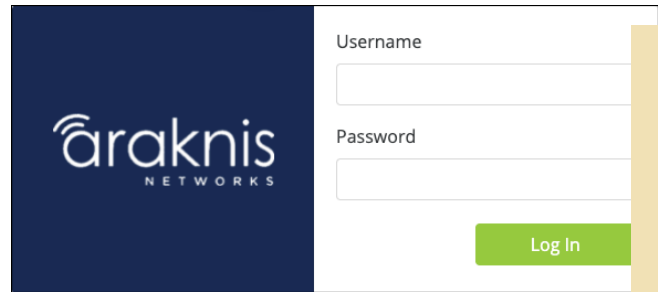

The image shows the Araknis Networks login interface. On the left is a dark blue square with the Araknis Networks logo. On the right is a white form with two input fields: 'Username' and 'Password'. Below the fields is a green 'Log In' button.

- **Tip:** - \_ Strong passwords are long and unrelated to the client's public details. For example, thepeppernipizzas is stronger and easier to remember than P@ssword or thesmiths.

## Other access methods: DHCP IP address

The switch is configured to DHCP by default so that the DHCP server can assign an IP address when the switch is connected to the network (the DHCP server is usually the router). This address can be used for accessing the web interface.

Use one of these methods to find the IP address of the switch:

- Check the device list in OvrC.
- Check the client table on your router.
- Use a network scanner (e.g. Fing) to scan the network. The Araknis switch manufacturer field displays SnapAV.
- See the highlighted field in the Fing screenshot to the right for an example of an Araknis device being identified.

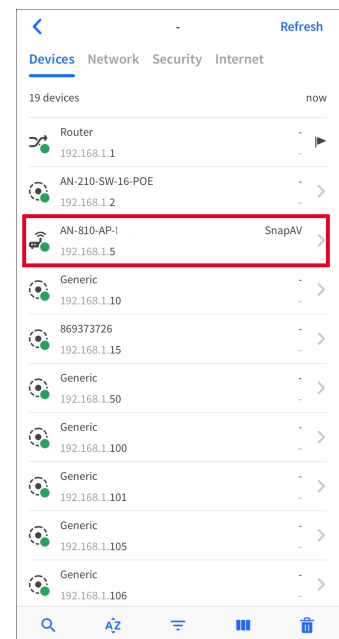

# Accessing the switch using the default IP address

If the switch is not given a DHCP address, or needs to be accessed while not connected to a network, you can configure your computer's network connection to access the switch using the default IP address, **192.168.20.254**.

1. Connect your PC to the switch using an Ethernet cable.
2. Open the Control Panel and click **Network and Internet**.

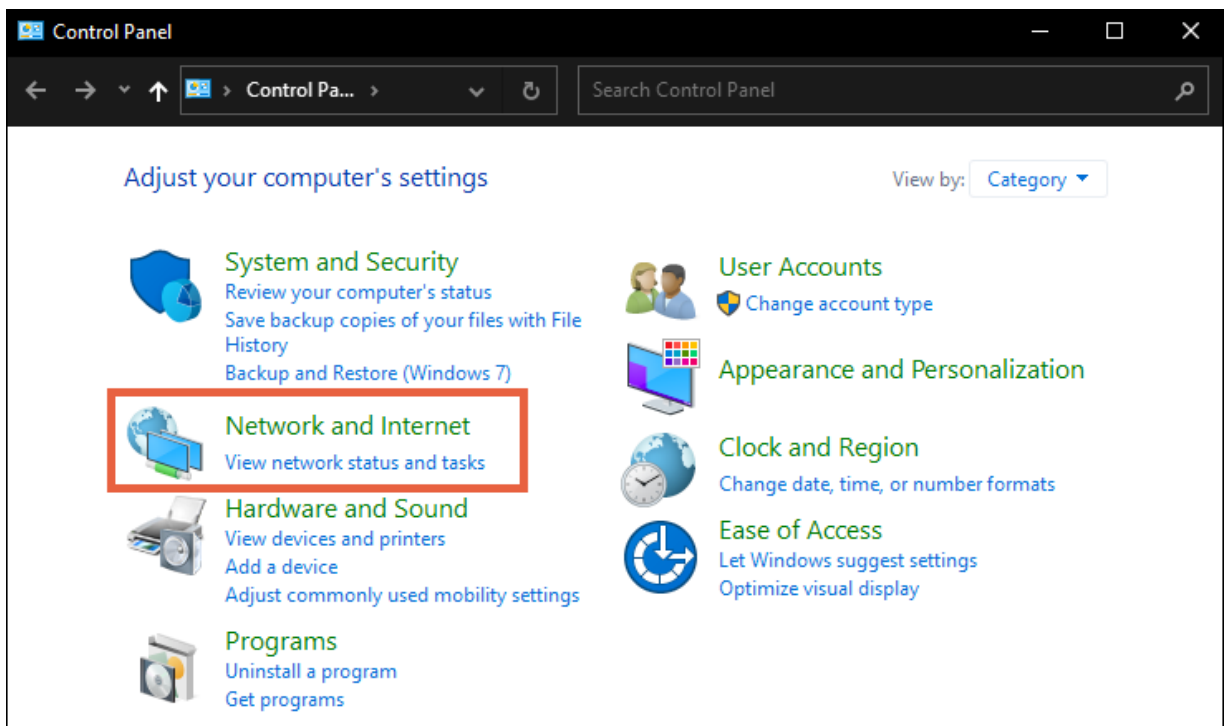

3. Click **Network and Sharing Center**.

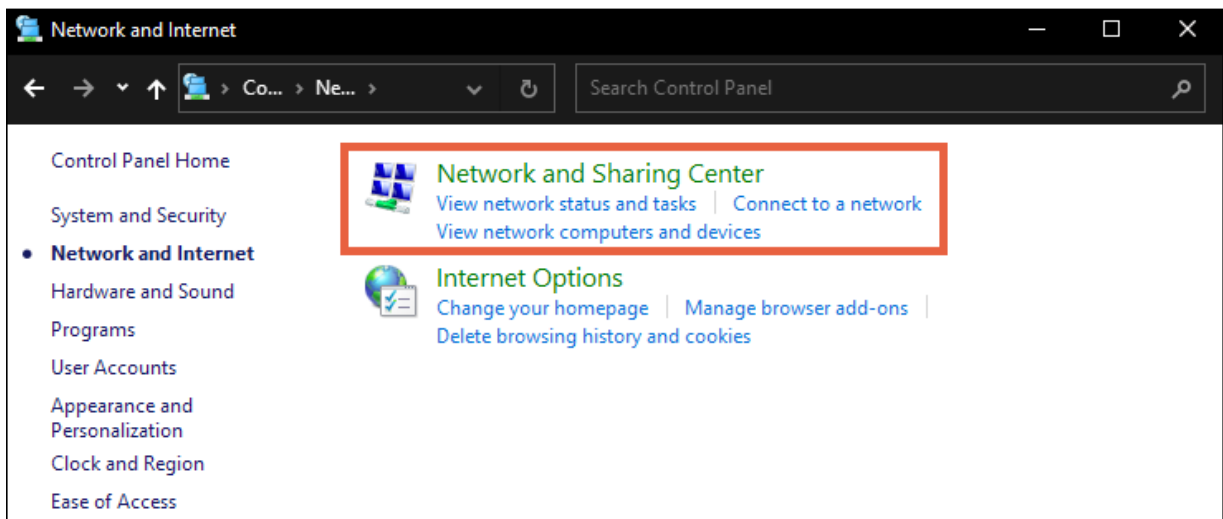

4. Click **Change adapter settings**.

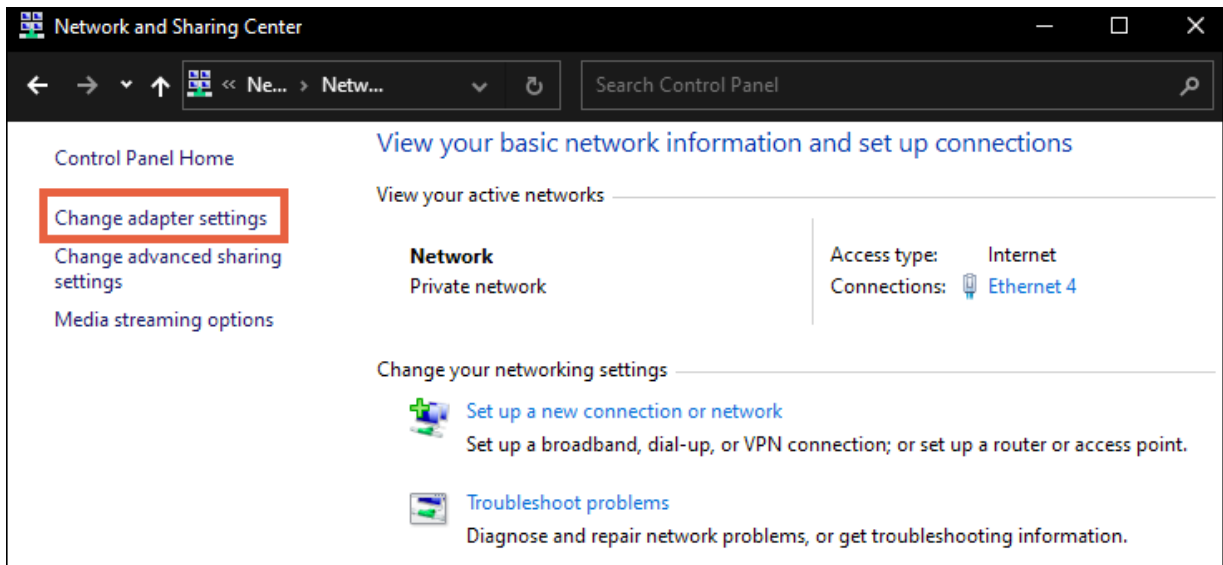

5. Right-click the icon for the wired network connection, then left-click **Properties**.

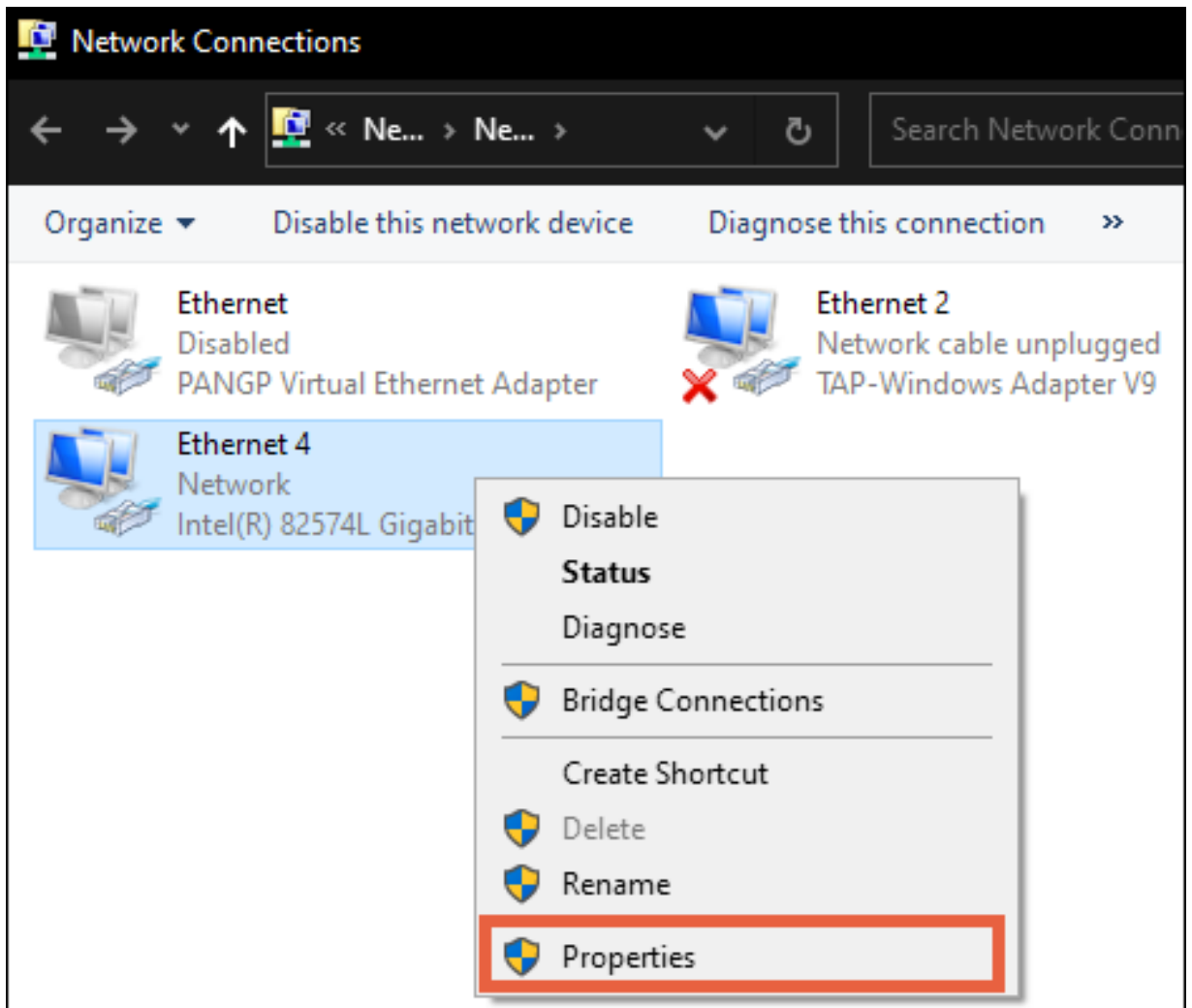

6. Select **Internet Protocol Version 4 (TCP/IPv4)**, then click **Properties**

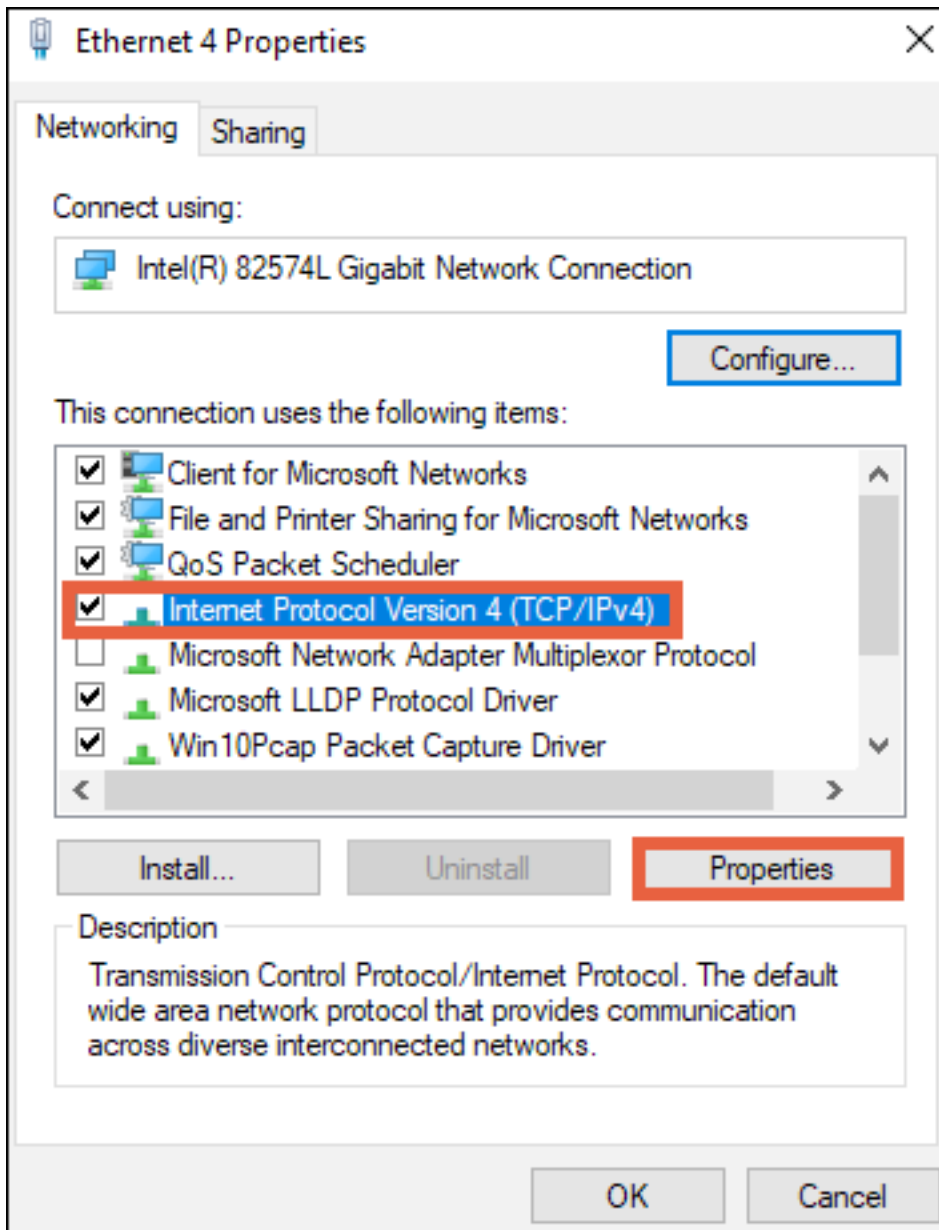

7. In the General tab, click **Use the following IP address:** and enter the IP address and subnet mask, then click **OK**.

<b>IP Address</b>	192.168.20.2
<b>Subnet Mask</b>	255.255.255.0

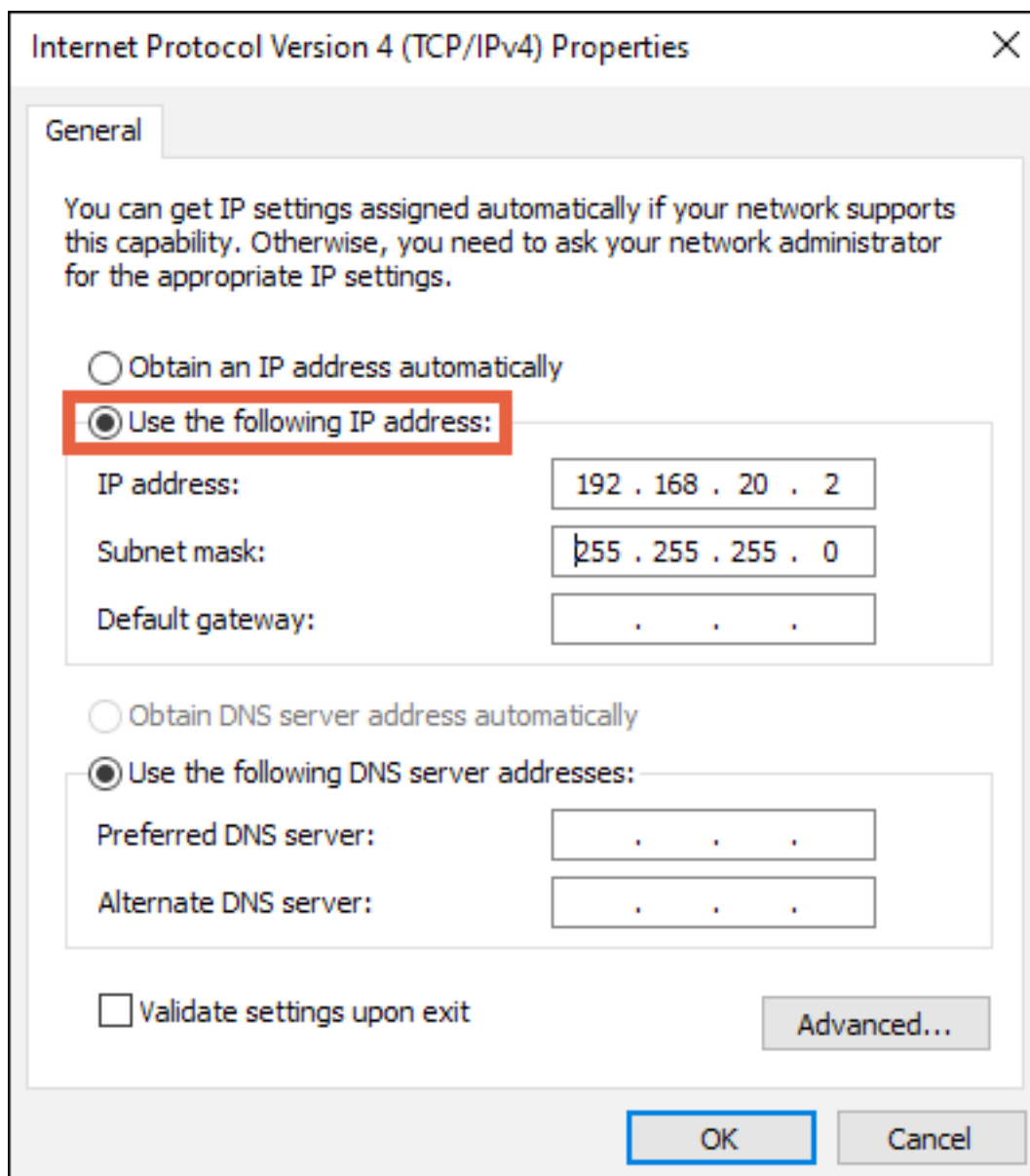

- Open a browser and navigate to <https://192.168.20.254/>. Log in using the default credentials:

<b>Username</b>	araknis
<b>Password</b>	araknis

- After configuring the switch, set your computer's IPv4 Properties back to Obtain an IP address automatically, then click **OK**.



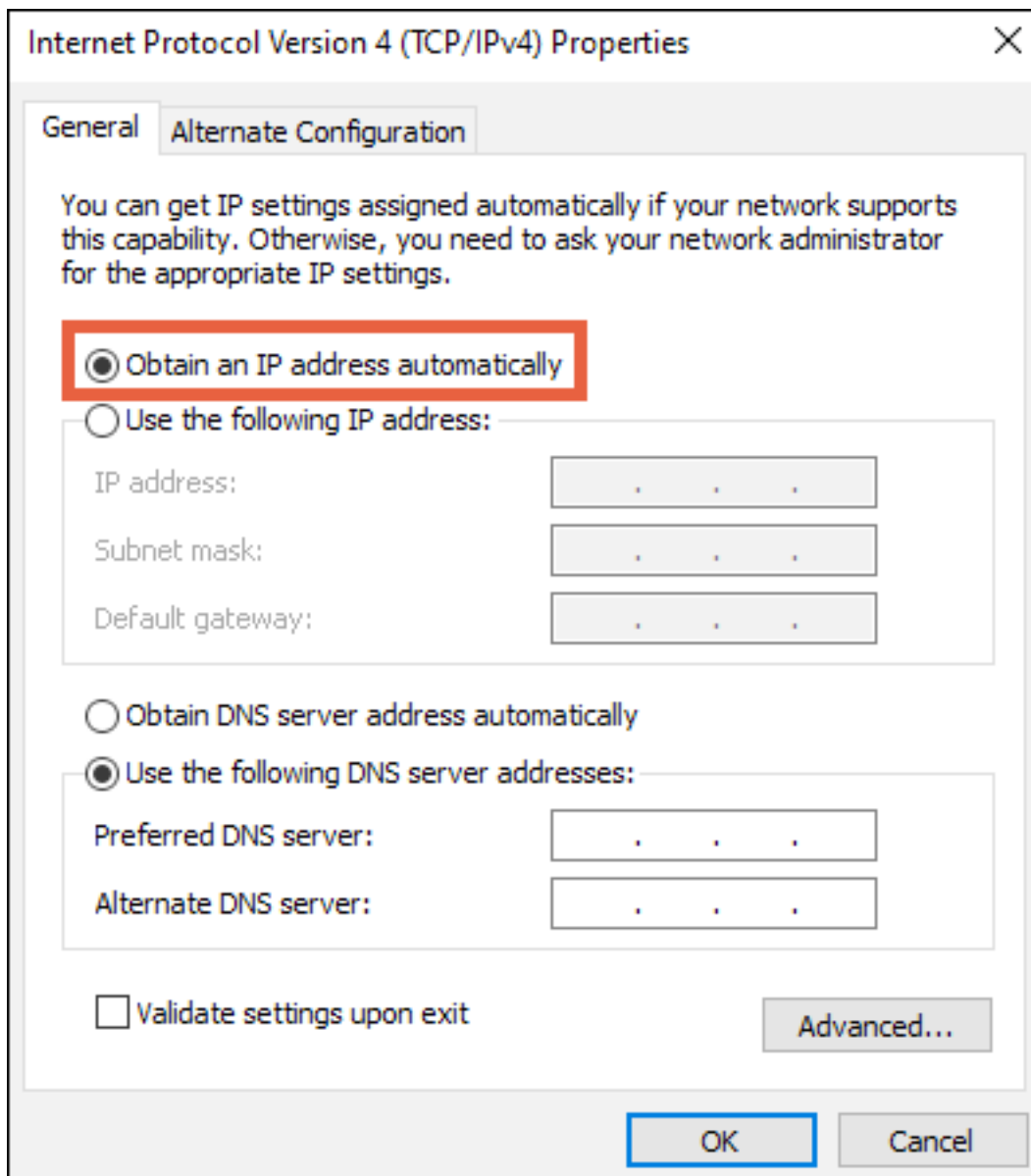

# Specifications

	<b>AN-620-SW-R-8- POE</b>	<b>AN-620-SW-R-24- POE</b>
<b>Ethernet ports</b>		
2.5G RJ-45 PoE ports	8	24
10G SFP+ ports	2	2
<b>Hardware performance</b>		
Flash memory	NAND: 128MB NOR:32MB	NAND: 128MB NOR:32MB
SDRAM	512MB	512MB
Packet buffer	12MB	16MB
MAC address table size	16K	32K
Switching capacity	80Gbps	160Gbps
Forwarding rate	59.52Mpps	119.04Mpps
<b>PoE features (802.3bt Type 3 PoE++)</b>		
Max power output per port	60W	60W
Total PoE power budget	240W	720W
Enable/Disable per port	Yes	Yes
Priority setting per port	Yes	Yes
Overload protection per port	Yes	Yes
Power level Setting per port	Yes	Yes
<b>Environmental</b>		
Dimensions (W x H x D)	443 mm (17.44")x 300 mm (11.81")x 44 mm (1.73")	443 mm (17.44")x 300 mm (11.81")x 44 mm (1.73")
Power supply	110-240V AC,50/60HZ	110-240V AC,50/60HZ

	<b>AN-620-SW-R-8- POE</b>	<b>AN-620-SW-R-24- POE</b>
Device power consumption	33.68W	70.77W
Max power consumption	42.1W	88.47W
Operating temperature	0-50°C	0-50°C

# Status

## System

This page provides an overview of the switch's configuration.

System Information	
System Name	AN-620-SW-R-8-POE-000DD9
Model Number	AN-620-SW-R-8-POE
Service Tag	ST [REDACTED]
Firmware Version	v1.00.10 (Sep 16 2022 03:43:32)
MAC Address	[REDACTED]
Device IP Address	192.168.1.150
Gateway	192.168.1.1
Active Interface	1/10
PoE Budget	0W of 240W(0.0% utilized)
Chassis Fans	2000RPM (Low)
VLANs in Database	1
STP	Root Status:True; BridgeID: [REDACTED]
IGMP	
L3 Interfaces	vlan1 - 192.168.1.150

- **System Name** – This is the name that the switch appears under when it is identified on the network. This field can be changed under **Settings > System**.
- **Model Number** – Use this field to verify the switch's model number. Notated as AN (Araknis) – SW (switch) – R/F (rear or front-facing ports) – X (the number of RJ-45 ports the switch has) –POE (Power-over-Ethernet).
- **Service Tag** – A unique identifying number that is used to add the switch to OvrC, manually.
- **Firmware Version** – Displays the firmware version installed on the switch. Use OvrC to verify if the switch is up to date and update the switch if it isn't.

- **MAC Address** — A unique identifier that appears in network scans. This address is required if the switch is being manually added to OvrC.
- **Device IP Address** — Displays the IP address of the switch.
- **Gateway** — Displays the IP address of the router.
- **Active Interface** — The number of ports that detect a connection compared to the total number of ports on the switch.
- **PoE Budget** — The amount of Power-over-Ethernet being currently used on the switch.

**Pro Tip:** Do not use more than 80% of the total budget. When calculating the budget, use the total possible amount of power the connected devices may draw.

- **Chassis Fans** — Shows the rotations per minute (RPM) of the fan and gauge how high the use of the fans is, in parenthesis. Low, Medium, High, Max, or OTP (Over Temperature Protection). The switch stays in OTP until the system temperature falls within the normal range.
- **VLANs in Database** — Displays the number of VLANs that are configured on the switch.
- **STP** — Provides details about the Spanning Tree Protocol (STP) configuration on the switch. See **Switching > Spanning Tree Protocol** for more information.
- **IGMP** — Provides details about the Internet Group Management Protocol (IGMP) configuration on the switch. See **Switching > IGMP Snooping** for more information.
- **L3 Interfaces** — Displays the DHCP servers the switch is interacting with.

## Ports

This page provides information about specific switchport configurations. Refresh the page to update the page.

Physically Connected Clients									
Interface	Name	Link Status	IP Address (LLDP)	MAC Address	Up Time (D:H:M)	PoE	VLAN	TX/s	RX/s
0/1	Port 1	1Gbps			00:17:46		1	138.4 B	647.5 B
0/2	Port 2	down			00:00:00		1	0.0 B	0.0 B
0/3	Port 3	down			00:00:00		1	0.0 B	0.0 B
0/4	Port 4	down			00:00:00		1	0.0 B	0.0 B
0/5	Port 5	down			00:00:00		1	0.0 B	0.0 B
0/6	Port 6	down			00:00:00		1	0.0 B	0.0 B
0/7	Port 7	1Gbps			00:00:02	4W	1	895.0 B	52.7 B
0/8	Port 8	down			00:00:00		1	0.0 B	0.0 B
0/9	Port 9	down			00:00:00	Not Supported	1	0.0 B	0.0 B
0/10	Port 10	down			00:00:00	Not Supported	1	0.0 B	0.0 B

- **Interface** – The number assigned to the port of the switch. The SFP ports are always the last two ports.
- **Name** – The assignable name for the port. Edit the name at **Settings > Ports > General**.
- **Link Status** – Displays the connection speed between the switch and the connected device. If there is no connection status is “down.”
- **IP Address (LLDP)** – Displays the IP address of the connected device (learned by LLDP).
- **MAC Address** – The MAC address of the device connected to the port.
- **Up Time (D:H:M)** – The amount of time the switch has detected a connection to the device in Days:Hours:Minutes.
- **PoE** – The amount of PoE power the switch is delivering to the connected device.
- **VLAN** – The VLAN ID assigned to the port.
- **TX/s** – The number of bytes, in seconds, being transmitted on the port.
- **RX/s** – The number of bytes, in seconds, being received on the port.

# Settings

## System

Use this page to update the general configuration of the switch. Below are the configurable settings and best practices.

Click the **Apply** button at the top of the page to save changes.

AN-620-SW-R-8-POE	Cancel	Apply
-------------------	--------	-------



### Edit Password



#### Edit Password

Current Password 



---

New Password  Confirm Password 

**Pro Tip:** Strong passwords are long and unrelated to the client's public details. For example, thepepperonipizzas is stronger and easier to remember than P@ssword or thesmiths.

## Edit Username



### Edit Username

New Username 

There is only one configurable user for switch access. The username should be unique and standardized across all devices.

## General Device Information

### General Device Information

Friendly Name 	Device Location 	System Name 
<input type="text" value="AN-620-SW-R-8-POE"/>	<input type="text"/>	<input type="text" value="AN-620-SW-R-8-POE-000DD9"/>

Device Notes 

- **Friendly Name** – Give a name that makes the switch easily identifiable. Such as “Core Switch - Rack.”
- **Device Location** – Enter where the switch is located.
- **System Name** – This is the name that the switch appears under during network scans by other applications. This name should be unique to the switch.
- **Device Notes** – Enter additional configuration notes that wouldn’t be displayed on the **Status > System** page. Such as what a VLAN is being used for on this switch.

**Pro Tip:** If you’re using OvrC, these notes should be entered there as well.



## LEDs

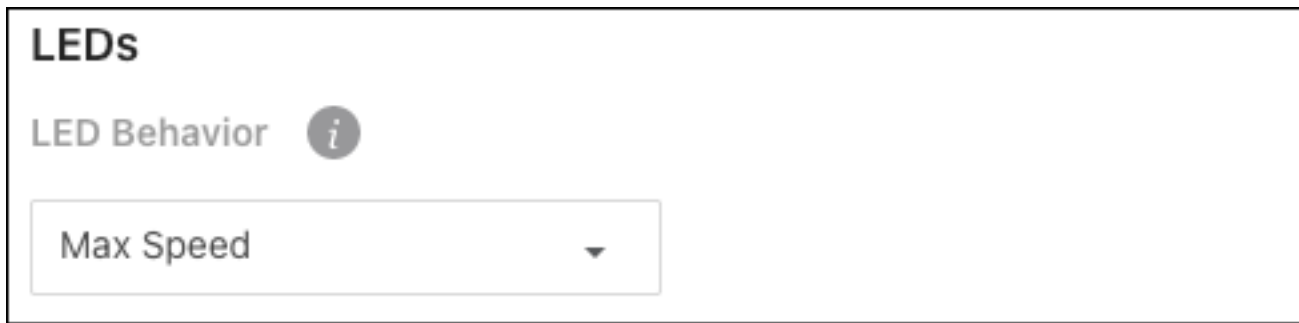

This setting determines the behavior of the **Speed/PoE** LED on the front of the switch.

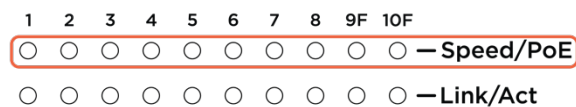

### Options include:

- **Max Speed** – Illuminates if the connection to the device is at the maximum possible speed.
- **PoE** – Illuminates if the switch is providing power to the connected device.
- **Disabled** – Turns the LED off.

**Pro Tip:** The LED Behavior should be standardized across all switch installations. Be sure to leave notes about the LED Behavior if it's not standardized.

## Adjust Time Zone

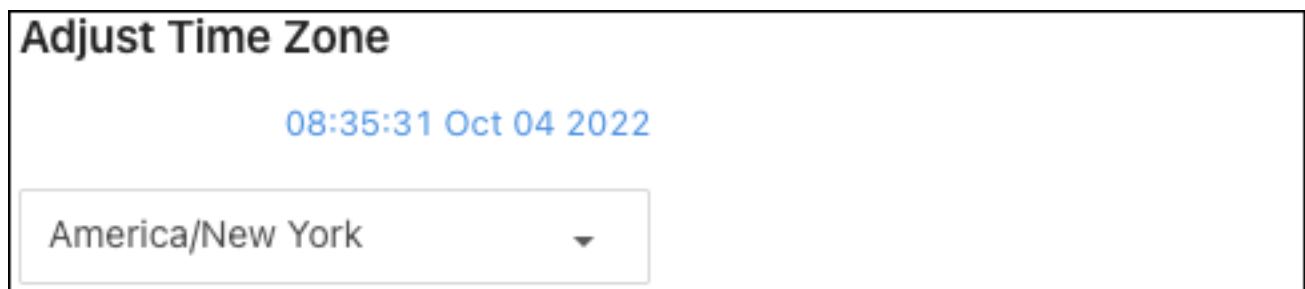

Configure the Time Zone that the switch is physically installed under.

## LAN

**Pro Tip:** Leave the switch as DHCP and make a MAC or IP reservation in the router.

## LAN

Mode *i*

DHCP ▼

IP Address *i*

192.168.1.150

Subnet Mask *i*

255.255.255.0

Gateway *i*

192.168.1.1

Primary DNS Server *i*

8.8.8.8

# Ports

## General

### Port Summary

Use this page to quickly edit port settings.

Port Summary										Port Details	Mirror	Mirror Summary	Link Aggregation	Link Aggregation Statistics
Filter By										...				
Enable	Interface	Name	Type	Physical Mode	Physical Status	Auto-Negotiate Capabilities	STP Mode	Link Status	Action	OPTIONS				
<input checked="" type="checkbox"/>	0/1	Port 1	Normal	Auto	1Gbps	100h, 100f, 1G, 2.5G	Enabled	line protocol is up (connected)	...	...				
<input checked="" type="checkbox"/>	0/2	Port 2	Normal	Auto	Not Connected	100h, 100f, 1G, 2.5G	Enabled	line protocol is down (not connected)	...	...				

Click the **Enable** toggle to enable or disable a port.

Use the **Options** (⋮) button to select multiple ports for configuration or the **Action** button to edit an individual port. Configurable settings appear in the Edit Port Configuration window.

### Edit Port Configuration

Port Configuration Selected: 1

Enable ⓘ

Name ⓘ

Physical Mode ⓘ  Auto Negotiate  Speed

Click the **Apply** button at the top of the page to save changes.

AN-620-SW-R-8-POE

### Configurable settings include:

- **Enable** – Toggle to allow traffic to pass through the port. Disable the port to prevent someone from plugging additional devices into the switch or to troubleshoot potential issues with a connected device.
- **Name** – Enter an easily identifiable name for the device connected to the port.
- **Physical Mode** – Configure the port speed and duplex mode.
  - **Auto Negotiate** – Advertises the duplex mode and speed for an auto-negotiation process with the device connected to the port. Click the “x” on the speed and duplex modes you do not want the switch to advertise.
  - **Speed** – Select speed to force the port to 100 Mbps half or full duplex.
- **STP Mode** – Toggle to enable or disable STP on the port.
- **Link Trap** – Toggle to enable or disable the port from broadcasting if it has a connection or not.
- **MTU (Maximum Transmission Unit)** – Enter the value for the largest possible packet size, in bytes, that a port can transmit.
- **Flow Control** – Use this feature to manage the data transfer rate between the switch and connected device(s). Flow control can be configured to only send or receive flow control packets. It can also be set to both.

**Pro Tip:** Leave flow control to the default **None** unless you have a specific application for the feature.

- **Broadcast Storm Recovery Level** – Enable to limit the amount of broadcast frames accepted and forwarded by the port by percentage, BPS (bits per second), or PPS (packets per second).
- **Multicast Storm Recovery Level** – Enable to limit the amount of multicast frames accepted and forwarded by the port by percentage, BPS (bits per second), or PPS (packets per second).

- **Unicast Storm Recovery Level** – Enable to limit the amount of unicast frames accepted and forwarded by the switch by percentage, BPS (bits per second), or PPS (packets per second).

## Port Details

Use this page to quickly view port information such as Physical Address, Port List Bit Offset, and the Interface Index. Use the **Options** (⋮) button to refresh the page.

Port Summary	Port Details	Mirror	Mirror Summary	Link Aggregation	Link Aggregation Statistics
Filter By <input type="text"/>					⋮ OPTIONS
Interface	Name	Physical Address	PortList Bit Offset	Interface Index	
0/1	Port 1	XXXXXXXXXX	1	1	
0/2	Port 2	XXXXXXXXXX	2	2	
0/3	Port 3	XXXXXXXXXX	3	3	

The physical address is the MAC address for the individual port.

## Mirror

Use port mirroring to mimic the traffic flowing through one port to another. Port mirroring is typically used to capture a recording of network traffic for troubleshooting purposes.

### To configure port mirroring:

1. Select a **Session ID**. You cannot have multiple sessions with the same ID. If you have no current port mirroring sessions, use Session ID 1.

You do not have to click Enable. This toggle is automatically enabled after you save the session settings.

2. Select a **Destination Type**. This is typically **Interface**.
3. Enter the **Port** number to receive transmit/receive data from the **Source Ports**. For example, if port 3 has a PC running Wireshark for packet capture, enter 3 in the Port field.

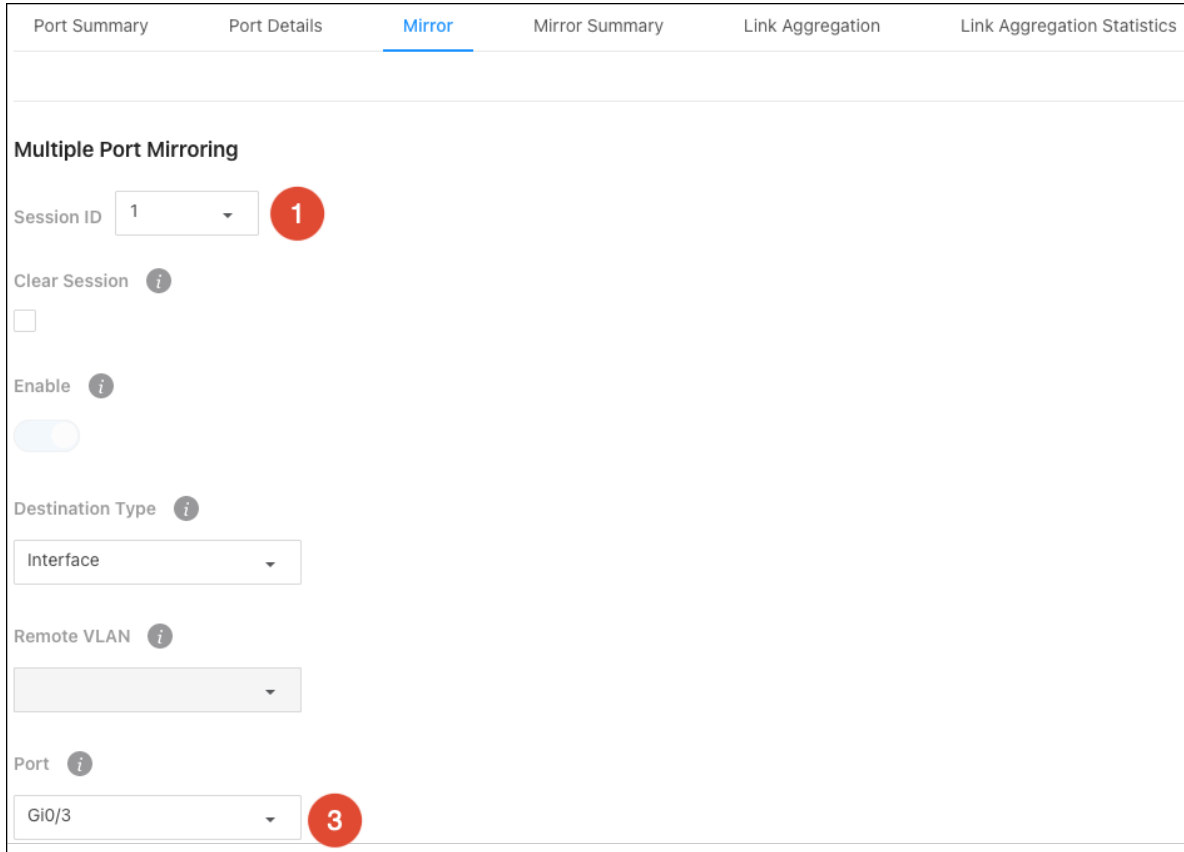

4. Click the **Options** (...) button and select **Add** to select the port(s) you want to mirror.

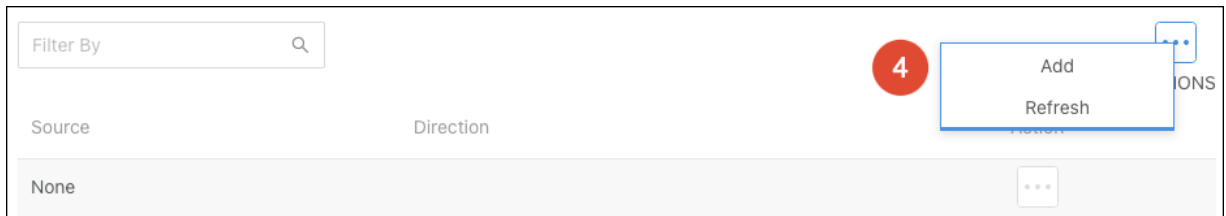

5. In the new window, select **Interface** as the Type.
6. Use the **Available Source Port(s)** dropdown to select the port(s) to mirror.

7. For **Direction**, select whether you want to mirror the packets being received (Rx), transmitted (Tx), or both (Tx/Rx), then click **Add**.

**Add Source Configuration**

Type ⓘ

None  Remote VLAN  Interface **5**

Available Source Port(s) ⓘ

**6**

Direction ⓘ

Tx/Rx  Rx  Tx **7**

8. Click **Apply** at the top of the page. After the page refreshes Enable will be toggled on.

**To disable a port mirroring session:**

Select the **Session ID** you wish to end and click the **Clear Session** checkbox. Then click **Apply** at the top of the page.

AN-620-SW-R-8-POE Cancel Apply

Port Summary Port Details **Mirror** Mirror Summary Link Aggregation Link Aggregation Statistics

---

**Multiple Port Mirroring**

Session ID

Clear Session i

### Mirror Summary

Use this page to view configured port mirroring sessions. Use the **Options** (⋮) button to refresh the page.

Port Summary Port Details Mirror **Mirror Summary** Link Aggregation Link Aggregation Statistics

---

**Port Mirroring Summary**

Filter By  ⋮

Session ID	Enable	Probe Port	Remove RSPAN Tag	Src VLAN	Mirrored Port	Reflector Port	Src RVLAN	Dst RVLAN	OPTIONS Direction
1	Disabled		False	0			0	0	
2	Disabled		False	0			0	0	

### Link Aggregation

Use Link Aggregation Groups (LAG) to combine the throughput of multiple ports.

#### To configure a LAG:

1. Click the **Options** (⋮) button to select multiple LAGs or use the **Action** button to configure a single LAG.
2. Verify **Enabled** is toggled on.



3. Enable or disable STP based on the networking needs.
4. Select a Link Aggregation Type. LACP is recommended.
  - **LACP** (Link Aggregation Control Protocol) broadcasts that the connection type is a LAG to the switch you're connecting to for automatic configuration.
  - **Manual** requires manual LAG configuration on the switch you're connecting to.
5. Enable or disable **Link Trap** based on the network's needs.
6. Leave **Load Balance** at the default (Source/Destination MAC, VLAN, Incoming Port), unless you have specific requirements.

The selections are the information the switch uses to determine how to load balance the throughput of the LAG.

7. Adjust the members of the port channel (ports 3 and 4 used in the example). Use the checkboxes to select a port and the directional arrows to add/remove ports.

**Edit Port Channel** ⓧ

Port Channel Selected: 1

Port Channel Name ⓘ

LAG 1

Enable ⓘ

2

STP Mode ⓘ

3

Link Aggregation Type ⓘ

LACP  Manual  Disabled 4

Link Trap ⓘ

5

Load Balance ⓘ

Source/Destination MAC, VLAN, Incoming Port 6

8. Click **Save** to close the window, then **Apply**.

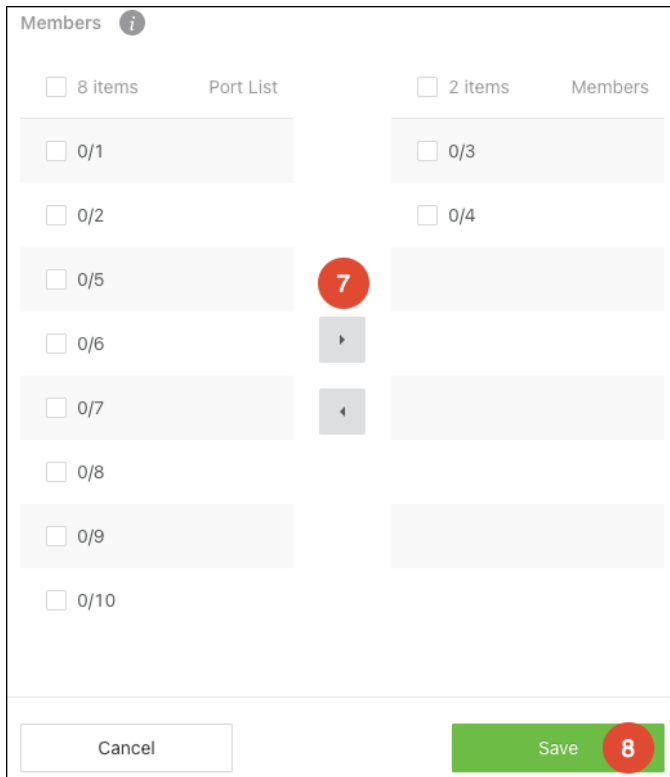

### General > Link Aggregation Statistics

Use this page to view information about configured LAGs. Use the **Options** (⋮) button to refresh the page.

Interface	Name	Channel Name	Type	Flap Count
po1	LAG 1	po1	Port Channel	1
po2	LAG 2	po2	Port Channel	1
po3	LAG 3	po3	Port Channel	1
po4	LAG 4	po4	Port Channel	1

## VLANs

### Database

Use this page to add and view VLANs that have been configured on the switch, and to enable or disable **Remote Switched Port Analyzer** (RSPAN).

VLANs must still be applied to ports on the **VLANs > Switchport Configuration** page.

RSPAN allows you to mirror traffic from multiple source ports (or from all ports that are members of a VLAN) from different network devices and send the mirrored traffic to a destination port (a probe port connected to a network analyzer) on a remote device.

The mirrored traffic is tagged with the RSPAN VLAN ID and transmitted over trunk ports in the RSPAN VLAN.

VLAN ID	Name	RSPAN	Action
1	default	<input type="checkbox"/>	...

You can use the RSPAN toggle to enable or disable the feature or use the **Options** (⋮) button to select multiple VLANs to enable RSPAN on.

Use the **Actions** button to select an individual VLAN and give it a meaningful **Name**.

Use the **Options** (⋮) button to add a new VLAN ID to the switch.

Configure the VLAN in the router before configuring the VLAN in the switch.

### To add a VLAN(s) to the switch:

1. Click the **Options** (⋮) button, then click **Add**.
2. Enter the **VLAN ID**, within the range of 2-4093. Use "-" between numbers to indicate a range. Use "," to enter multiple VLAN IDs not adjacent to each other.
3. You can a meaningful **Name** for the VLAN or leave the field blank.
4. **Append** and/or **Add Zeros** in front of the VLAN ID. This allows the switch to quickly create identifiers if you're adding multiple VLANs at once.
  - **Append VLAN ID** – Checking this appends the VLAN ID after the name. For example, VLAN -> VLAN2.
  - **Add Zero in Front of ID** – Checking this adds zeroes in front of the VLAN ID, up to a total of 4 digits. For example, VLAN2 -> VLAN0002, VLAN123 -> VLAN0123. This only works when Append VLAN ID is selected.
5. Enable **RSPAN**, if desired.
6. Click **Add**, then **Apply** at the top of the page.





The screenshot shows a dialog box titled "Add VLAN" with a close button (X) in the top right corner. The dialog contains the following fields and controls:

- VLAN ID or Range**: A text input field containing "2,3", with a red circle "2" next to it.
- Name**: A text input field, with a red circle "3" next to it.
- Append VLAN ID**: A checked checkbox, with a red circle "4" next to it.
- Add Zero In Front of ID**: A checked checkbox, with a red circle "4" next to it.
- RSPAN**: A toggle switch that is currently off, with a red circle "5" next to it.
- Buttons**: A "Cancel" button and an "Add" button (highlighted in green), with a red circle "6" next to the "Add" button.

## Switchport Configuration

Use this page to quickly view and configure VLANs on specific ports. Use the **Options** (  ) button to modify multiple ports at once, or the **Action** button to edit a specific port.

VLAN IDs must be configured on the **VLANs > Database** page.

Database		Switchport Configuration		MAC Based VLAN		Reset					
<b>Switchport Configuration</b>											
Filter By <input type="text"/>											
											OPTIONS
Interface	Name	Switchport Mode	Access VLAN(U)	Trunk Native VLAN(U)	Allow Trunk VLANs(T)	Acceptable Frame Type	Ingress Filtering	Port VLAN ID	Untagged VLANs	Tagged VLANs	Action
0/1	Port 1	Trunk	-	1	1-3	Admit All	Disabled	-	-	-	
0/2	Port 2	Access	2	-	-	Only Untagged	Disabled	-	-	-	
0/3	Port 3	Access	3	-	-	Only Untagged	Disabled	-	-	-	

### Simple configuration

To quickly configure a port(s) for VLANs, set the **Switchport Mode** to **Trunk** or **Access**.  
Selecting Trunk automatically allows all the VLAN IDs configured in the switch to pass through the port. Connections to other switches are typically trunk ports.

### Edit Switchport Configuration ⓧ

Switchport Configuration Selected: 1

Switchport Mode ⓘ

Trunk

Trunk Native VLAN (Untagged) ⓘ

1

Allow Trunk VLANs (Tagged) ⓘ

1-3

Priority ⓘ

0

Cancel Save

Selecting Access requires you to select a single VLAN ID as the **Access VLAN (Untagged)**. This means that only packets tagged with the selected VLAN ID can pass through this switchport.

## Edit Switchport Configuration ⓧ

Switchport Configuration Selected: 2

Switchport Mode i

Access

Access VLAN (Untagged) i

2

Priority i

0

Cancel Save

## Complex configuration

If the port must pass multiple VLANs but not all, select **General** as the switchport mode.

### Configurable settings include:

- **Port VLAN ID (PVID)** – Select the VLAN ID assigned to untagged, or priority tagged frames received on this port.
- **Acceptable Frame Type** – Tell the port how to handle traffic with tagged frames. All tagged VLAN frames are forwarded in accordance with the IEEE 802.1Q VLAN standard. Options include:
  - **Admit All** – The port accepts priority tagged and untagged frames and assigns them the value of the PVID assigned to the interface.
  - **Only Tagged** – The port discards any untagged or priority tagged frames it receives.
  - **Only Untagged** – The port discards any tagged frames it receives.
- **Ingress Filtering** – Enable to discard tagged frames that aren't members of the VLAN ID assigned to the port. Leave this feature disabled to accept all tagged frames.
- **Untagged VLANs** – Enter a VLAN ID in the range 1 to 4093. Use '-' to specify a range and ',' to separate VLAN IDs or VLAN ranges in the list.
- **Tagged VLANs** – Enter a VLAN ID in the range 1 to 4093. Use '-' to specify a range and ',' to separate VLAN IDs or VLAN ranges in the list.



- **Priority** – The default 802.1p priority assigned to untagged packets arriving at the interface. 802.1p is a Quality of Service (QoS) value used to differentiate traffic.

### Edit Switchport Configuration ⊗

Switchport Configuration Selected: 3

Switchport Mode i

General

Port VLAN ID i

1

Acceptable Frame Type i

Admit All  Only Tagged  Only Untagged

Ingress Filtering i

Untagged VLANs i

1

Tagged VLANs i

2,3

Priority i

0

## MAC Based VLAN

Use this page to bind traffic from a MAC address to a VLAN ID.

### To configure a MAC based VLAN:

1. Click the **Options** (⋮) button, then **Add**.
2. Enter the **MAC address** you wish to bind to a VLAN ID, then select the **VLAN ID** to bind it to. Click **Add**.

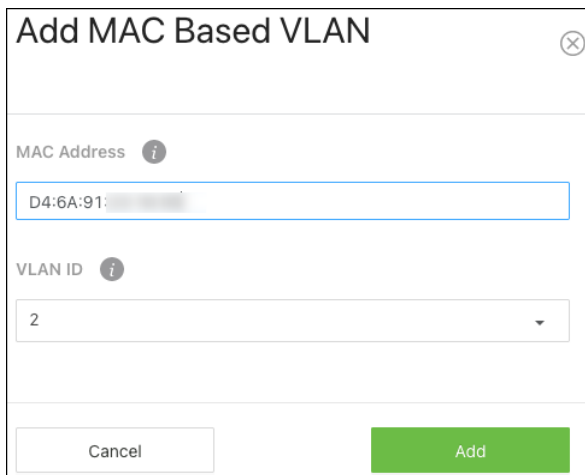

The screenshot shows a modal dialog box titled "Add MAC Based VLAN". It features a close button (X) in the top right corner. The dialog contains two input fields: "MAC Address" with a value of "D4:6A:91:..." and "VLAN ID" with a value of "2". Below the input fields are two buttons: "Cancel" and "Add".

3. Enable **Global MAC VLAN Mode**.
4. Select the **Interface** (switchport) to apply the MAC Based VLAN to.

5. Enable **Port Mode**, then click **Apply** at the top of the page.

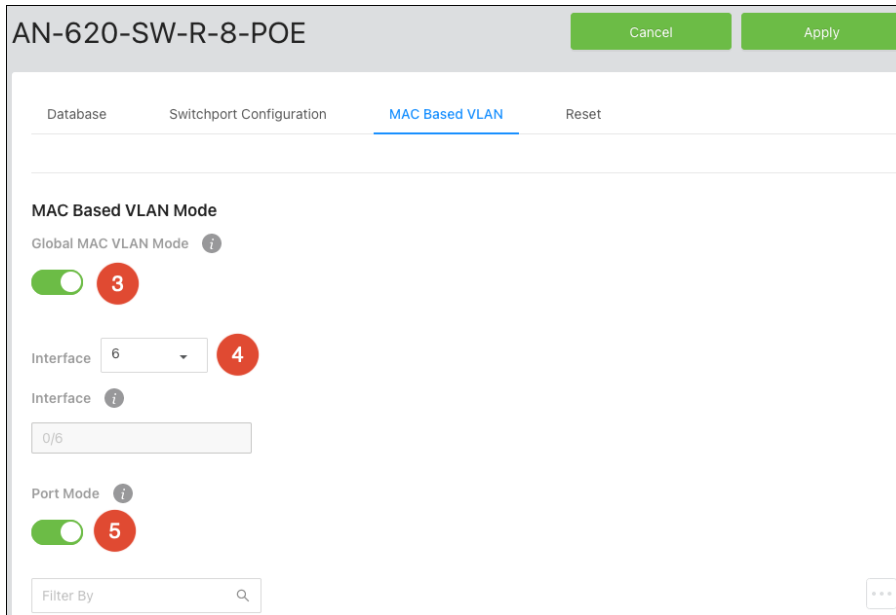

6. The MAC Based VLAN appears at the bottom of the page.

MAC	VLAN	Action
D4:6A:91: [REDACTED]	2	[...]

## Reset

Click the **Reset** button to reset all the VLAN settings on the switch.

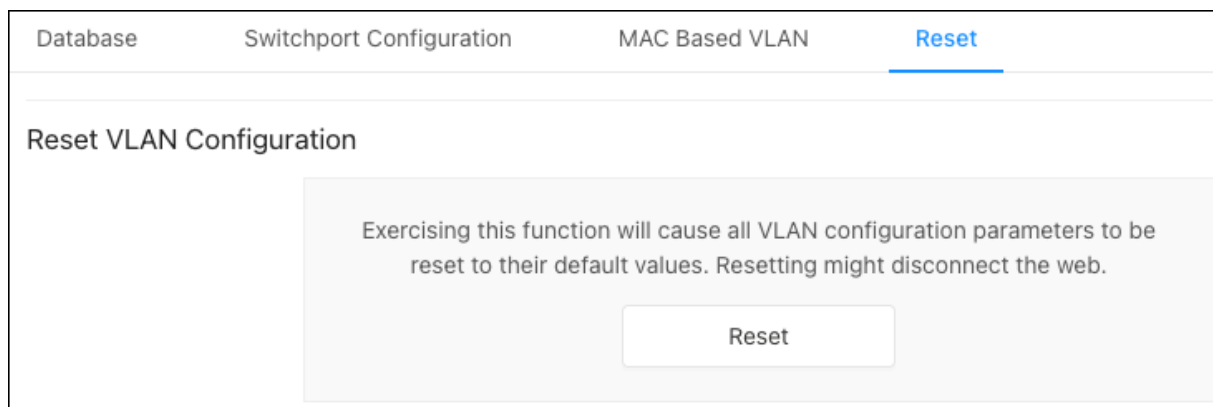

## PoE

### Port Configuration

Use this page to quickly enable/disable PoE on ports and view the PoE configuration on each port.

Use the **Options** (⋮) button to select multiple ports for configuration or the **Action** button to edit an individual port.

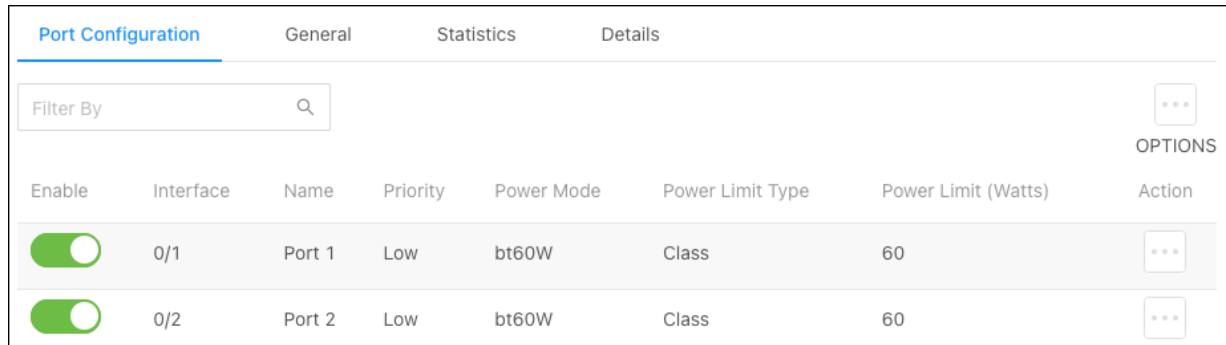

Port Configuration							
General							
Statistics							
Details							
Filter By <input type="text"/>							⋮
							OPTIONS
Enable	Interface	Name	Priority	Power Mode	Power Limit Type	Power Limit (Watts)	Action
<input checked="" type="checkbox"/>	0/1	Port 1	Low	bt60W	Class	60	⋮
<input checked="" type="checkbox"/>	0/2	Port 2	Low	bt60W	Class	60	⋮

### Configurable settings include:

- **Enable** – Toggle to enable/disable PoE on the port.
- **Priority** – Set a priority level for PoE power allocation. Higher priority levels should be reserved for devices that are critical for the system to operate, such as access points.
- **Power Mode** – Set the PoE power standard for the port. Selecting a PoE class supports the PoE+ power standard, which provides up to 60W of power. Legacy supports 3W – 15W of power. Supported power modes include:
  - bt60W (default)
  - at30W
  - af15W
  - Legacy
- **Power Limit Type** – Select the type of power limiting for the port. Options include:

- **Class (default)** – Follows the negotiated PoE class limitations.
- **User** – Follows the Power Limit (Watts) setting.
- **None** – No power limit.
- **Power Limit (Watts)** – Enter the maximum amount of watts that the port can support.
- **Detection Type** – Select a detection protocol for the port to use. Options include:
  - 4Pt-Dot3af (default)
  - 4Pt-Dot3af+Legacy
  - Legacy
  - None

## General

Use this page to configure global PoE settings for the switch. The top of the page displays PoE totals.

Port Configuration	General	Statistics	Details
Firmware Version	1.3.0.9		
Operational Status	On		
Total Power Available:	240 Watts		
Threshold Power:	216 Watts		
Consumed Power:	3.8 Watts		
Enable 	<input checked="" type="checkbox"/>		

### Configurable features include:

- **Enable** – Enable or disable PoE for the entire switch.
- **System Usage Threshold** – Enter the total percentage of the switch’s usable PoE budget. For example, setting the threshold to 90% means that only 90% of the switch’s total PoE budget can be used. This prevents the switch from being

overloaded.

- **Power Management Mode** — Select the method that the switch determines PoE. By default, the switch decides PoE power dynamically, but you can set it to static. Doing so requires manual wattage entry on the Port Configuration page.
- **Port Auto Reset Mode** — Enable or disable the ability for the switch to automatically reset a port.
- **Traps** — Enable to allow the switch to send alerts about PoE statuses, such as PoE being enabled or disabled on a port.
- **Fast PoE Mode** — Enable Fast PoE for the switch to provide PoE power before the boot process completes.
- **Perpetual PoE Mode** — Enable to allow the switch to continue providing PoE power if the switch is restarting.

## Statistics

Use this page to view PoE error counts when troubleshooting potential PoE issues.

An error on the switch confirms there is a PoE issue, but it does not mean the issue is caused by the switch. Troubleshoot the connected device and Ethernet cable.

Port Configuration		General	Statistics	Details		
Interface	Name	Overload Counter	Short Counter	Power Denied Counter	MPS Absent Counter	Invalid Signature Counter
0/1	Port 1	0	0	0	0	0
0/2	Port 2	0	0	0	0	0

### Counter explanations:

- **Overload Counter** – The number of times there has been a power overload.
- **Short Counter** – The number of times there has been a short-circuit condition.
- **Power Denied Counter** – The number of times the connected device has been denied power.
- **MPS Absent Counter** – The number of times power has stopped because the powered device couldn't be detected.
- **Invalid Signature Counter** – The number of times an invalid signature was received.

Signature detection is used to detect the presence of a powered device, where a resistance value on the connected device is expected to be found within a particular range.

## Details

Use the details page to gather information about the PoE status of each port. Click **Options** (⋮), then **Refresh** to update the page.

Port Configuration		General		Statistics		Details				
Interface	Name	High Power	Max Power (Watts)	Class	Output Voltage (Volts)	Output Current (mAmps)	Output Power (Watts)	Temperature (C)	Status	Options
0/1	Port 1	Disabled	60	Unknown	0	0	0	42	Searching	No Error
0/2	Port 2	Disabled	60	Unknown	0	0	0	42	Searching	No Error
0/3	Port 3	Disabled	60	4	54	70	3.8	40	Delivering Power	No Error

## Tools

### Firmware Management

Use this page to manually update the firmware on the switch. The image selected when loading the page is the active image. If the firmware fails to boot, the switch switches to the other image as a failsafe.

**Pro Tip:** Use OvrC to confirm if the switch is up to date. If not, click the Update button for OvrC to update the switch to the latest firmware. OvrC automatically switches between the active and backup images when performing upgrades.



**Dual Image**

	Name	Version	Size (Byte)	Created Time
<input checked="" type="radio"/>	image1	1.00.10.000000	29762556	Sep 16 2022 03:43:32
<input type="radio"/>	image2	1.00.00.000000	29770617	

**Manual Update**

## Configuration Management

Use this page to save a backup of the switch's configuration or to reset the switch to the default settings.

**Create Backup**

Save Configuration

---

**Restore Configuration File**

Choose File *No File Selected* Restore

---

**Reset to Default**

Reset to Default

## Diagnostic Utilities

### Ping

Use a ping test to measure the amount of time it takes to reach an address on the local network or the internet. You can enter the IP address or the hostname, such as `www.wikipedia.com`.

**Pro Tip:** Before selecting a DNS server, use a ping test to measure the fastest response time.

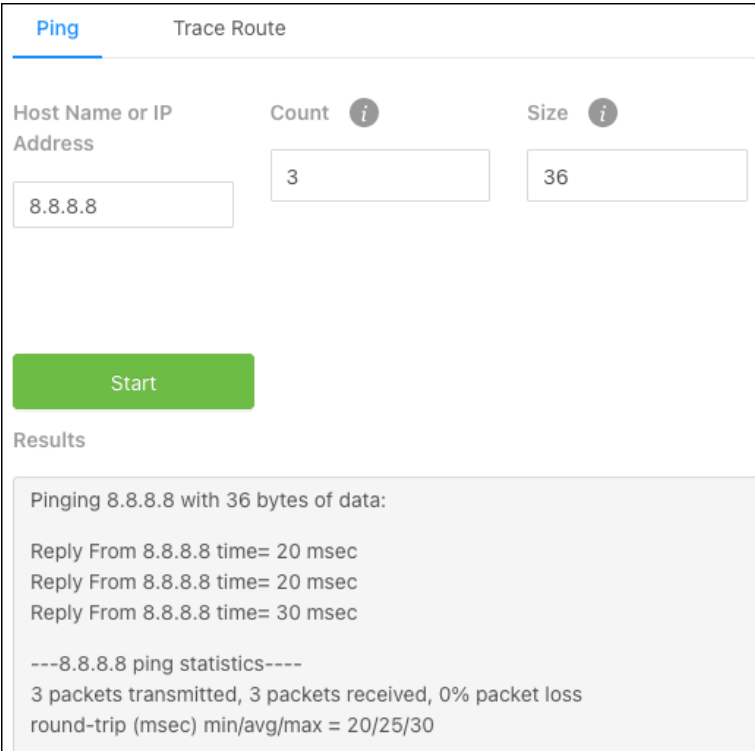

The screenshot shows a network utility interface with two tabs: "Ping" (selected) and "Trace Route". Under the "Ping" tab, there are three input fields: "Host Name or IP Address" containing "8.8.8.8", "Count" containing "3", and "Size" containing "36". Below these fields is a green "Start" button. The "Results" section displays the following text:

```
Pinging 8.8.8.8 with 36 bytes of data:  
Reply From 8.8.8.8 time= 20 msec  
Reply From 8.8.8.8 time= 20 msec  
Reply From 8.8.8.8 time= 30 msec  
---8.8.8.8 ping statistics---  
3 packets transmitted, 3 packets received, 0% packet loss  
round-trip (msec) min/avg/max = 20/25/30
```

### Traceroute

Use a traceroute to diagnose network interruptions between the switch and an address on the local network or the internet. You can enter an IP address or a hostname, such as `www.youtube.com`.

Ping **Trace Route**

Host Name or IP Address:

Probes Per Hop:  ⓘ

MaxTTL:  ⓘ

InitTTL:  ⓘ

Size:  ⓘ

## Advanced

### System

#### **Management Access**

Use the System Connectivity page to configure connection settings for the switch.

#### **Configurable settings include:**

- **Telnet** – Enable to allow telnet connections on port 23.
- **HTTPS** – Enable to require an HTTPS connection for the switch’s local interface. When enabled, you must type **https://** before the IP address in your browser’s address bar.
- **SSH** – Enable to allow SSH connections. You can specify the **port** to use and The **Session Timeout**, in seconds.

## **SNTP**

### **Global Configuration**

Use this page to configure the **Simple Network Time Protocol (SNTP)** to make the switch's clock time accurate to the millisecond.

The SNTP server the switch synchronizes to is configured on the **Server Configuration** tab.

#### **Configurable settings include:**

- **Client Mode** – Use the dropdown to determine how SNTP operates. Options include:
  - **Unicast** – Makes STNP operate in a point-to-point fashion. A unicast client sends a request to a designated server at its unicast address and expects a reply to determine the time, and potential round-trip delays to calculate an offset from the local time.
  - **Broadcast** – SNTP operates like it's multicast but uses a local broadcast address instead of a multicast address. The broadcast address has a single subnet scope, while a multicast address has an internet-wide scope.
  - **Disable** – Disables the SNTP protocol on the switch.
- **Port** – Enter a local UDP port to listen for responses and/or broadcasts.
- **Unicast Poll Interval (Seconds)** – Enter the number of seconds between unicast poll requests, expressed as a power of two when configured in unicast mode.
- **Unicast Poll Timeout (Seconds)** – Enter the number of seconds between broadcast poll requests, expressed as a power of two when configured in unicast mode. Broadcasts received prior to the expiry of the interval are discarded.
- **Broadcast Poll Timeout (Seconds)** – Enter the maximum amount of time to wait for a poll to complete, between 1 - 30 seconds

- **Broadcast Delay Time (microseconds)** – Enter the maximum amount of time the SNTP client needs to wait for a response from the server, between 1000 -15000 microseconds.
- **Broadcast SNTP Server** – Displays the SNTP server of broadcast.
- **Unicast Poll Retry** – Enter the number of times to retry a request to an SNTP server after the first time-out before attempting to use the next configured server when configured in unicast mode.
- **Number of Servers Configured** – Displays the number of SNTP servers configured on the Server Configuration tab.

## Global Status



Use this page to view the SNTP server configuration of the switch.

Global Configuration	<u>Global Status</u>	Server Configuration	Server Status
<b>SNTP Global Status</b>			
Version	4		
Supported Mode	Unicast/Broadcast		
Last Update Time	14:01:32 America/Los_Angeles(UTC-7:00) Oct 13 2022		
Server IP Address	time.google.com		
Address Type	DNS		
Unicast Server Max Entries	2		
Unicast Server Current Entries	1		

## Server Configuration

Use this page to add SNTP servers and configure the priority of which server should be used first, and which should be used in case the servers with a higher priority cannot be contacted.

Use the **Options** (⋮) button to refresh the page, add, or select multiple servers to configure. Use the **Action** button to edit or delete an existing SNTP server.

Global Configuration	Global Status	<u>Server Configuration</u>	Server Status		
<b>SNTP Server Configuration</b>					
Filter By <input type="text"/>			 <b>OPTIONS</b>		
SNTP Server	Type	Port	Priority	Version	Action
time.google.com	DNS	123	1	4	

### To add an SNTP server:

1. Click **Options** (⋮), then **Add**.
2. Enter an SNTP Server Name or IP Address.
3. Select an **SNTP Server Type**, meaning whether it's an IPv4, IPv6, or DNS address.
4. Enter a UDP Port the SNTP server to communicate on.
5. Enter the **Priority** level that the SNTP server should be used. If it's a fallback address in case the default SNTP server fails, enter 2.
6. Enter the protocol **Version** number. The default is 4.
7. Click **Add**, then **Apply** at the top of the page.

The screenshot shows a dialog box titled "Add SNTP Server" with a close button (X) in the top right corner. The dialog contains several input fields and a radio button group, each with a red circle containing a number from 1 to 7. The fields are: "SNTP Server Name or IP Address" (1) containing "time.microsoft.com" (2); "SNTP Server Type" (3) with radio buttons for "IPv4", "IPv6", and "DNS" (selected); "Port" (4) containing "123"; "Priority" (5) containing "2"; and "Version" (6) containing "4". At the bottom, there is a "Cancel" button and a green "Add" button (7).



## Server Status

Use this page to see the last updated time the switch has received from the configured SNTP server(s) and how many requests the switch has made to the server(s).

Global Configuration	Global Status	Server Configuration	<u>Server Status</u>
<b>SNTP Server Status</b>			
Filter By <input type="text"/>			 OPTIONS
Address	Last Update Time	Requests	
time.google.com	14:11:37 America/Los_Angeles(UTC-7:00) Oct 13 2022	1	
time.microsoft.com		0	

# Switching

## IGMP Snooping

### Configuration

Use this page to enable IGMP Snooping on the switch and view related counts.

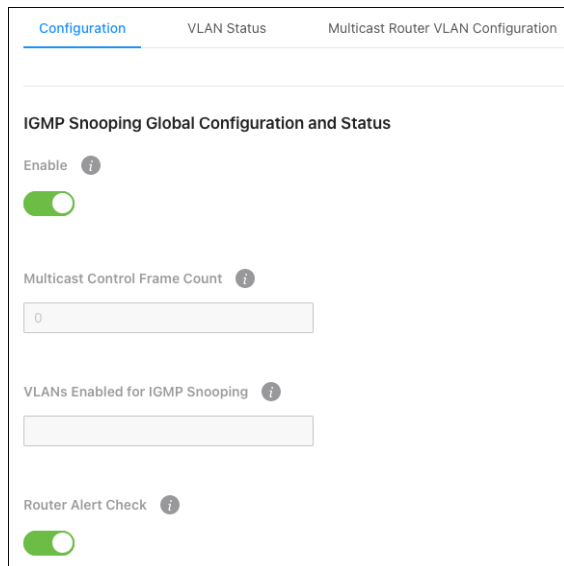

#### Configurable settings:

- **Enable** – Enables/disables IGMP snooping on the switch.
- **Router Alert Check** – Enable for the switch to inspect packets when they are being forwarded, even though the packet is not directly addressed to this switch.

#### Read-only fields:

- **Multicast Control Frame Count** – The number of multicast frames the switch has processed.
- **VLANs Enabled for IGMP Snooping** – The number of VLANs configured on the switch for IGMP snooping.

### VLAN Status

Use this page to add VLANs to the IGMP configuration of the switch.

#### To configure a VLAN for IGMP snooping:

1. Click **Options** (⋮), then **Add**.
2. Select a **VLAN ID**.
3. Enable **Fast Leave** if the multicast streams are each more than half the available bandwidth of the switch port.
4. The **Max Response Code** field displays the maximum time allowed before the switch sends a responding report. The default value is 100.
5. Click **Add**, then **Apply** at the top of the page.

VLANs configured for IGMP Snooping appear at the bottom of the page.

Configuration		VLAN Status		Multicast Router VLAN Configuration	
<b>IGMP Snooping VLAN Status</b>					
Filter By <input type="text"/>					⋮
					OPTIONS
VLAN ID	Enable	Fast Leave Enabled	Max Response Code	Max Response Time (Seconds)	Action
2	<input checked="" type="checkbox"/>	Disabled	100	10.00	⋮

## Multicast Router VLAN Configuration

Use this page to configure VLANs for multicast routing. When enabled, multicast routers learn which multicast groups are active by periodically checking with each member of the multicast group. Read [Understanding Multicast & IGMP](#) for more information about multicast groups.

Interface	Name	VLAN IDs	Learned VLAN IDs	Action
0/1	Port 1	1		...
0/2	Port 2	2		...

### To configure multicast routing:



1. Use the **Options** (⋮) button to configure multiple ports or the **Actions** button to edit a single port.
2. Select the **VLAN ID(s)** you want the port to act as the multicast router for, then click the **right arrow** to add them.

3. Click **Save**, then **Apply** at the top of the page.

### Edit Multicast Router VLAN Configuration

Multicast Router VLAN Configuration Selected: 2

VLAN IDs ⓘ

<input checked="" type="checkbox"/> 1/3 items	VLAN List	<input type="checkbox"/> 0 item	Members
<input checked="" type="checkbox"/>	2		
<input type="checkbox"/>	1		
<input type="checkbox"/>	3		
			 No Data
			

## IGMP Snooping Querier

### VLAN Configuration

Use this page to add VLANs that the switch should act as the IGMP querier for. To learn more about IGMP queriers, read [Understanding Multicast & IGMP](#).

**Caution:** Only enable **IGMP Snooping Querier** on the switch where your IGMP topology starts, called the **core IGMP switch**. This IGMP querying switch asks each device on the network which multicast traffic they want.

#### To add a VLAN to the switch's IGMP snooping querier configuration:

1. Click the **Options** button () , then **Add**.
2. Select a **VLAN ID**.
3. Select the **IGMP Version** to use when making inquiries.
4. The **Querier VLAN IP Address** is typically left at the default address (0.0.0.0), but it can be changed.
5. For the **Query Interval**, enter the amount of time (in seconds) that the IGMP snooping querier should wait between sending periodic IGMP queries. The default value is 125.
6. The **Query Expiry Interval** is the amount of time (in seconds) that the device remains in non-querier mode after it has discovered that there is a multicast querier in the network. The default value is 255.

7. Click **Add**, then **Apply** at the top of the page.

### Add IGMP Snooping Querier VLAN Configuration ⓧ

VLAN ID i  
2 2

IGMP Version i  
 IGMP v1  IGMP v2  IGMP v3 3

Querier VLAN IP Address i  
0.0.0.0 4

Query Interval (Seconds) i  
125 5

Query Expiry Interval (Seconds) i  
255 6

Cancel 7 Add

Configured VLANs are listed at the bottom of the page.

VLAN Configuration VLAN Status

#### IGMP Snooping Querier VLAN Configuration

Filter By  🔍 ⋮ **OPTIONS**

VLAN ID	Querier VLAN IP Address	IGMP Version	Query Interval	Querier Expiry Interval	Action
2	0.0.0.0	IGMP v2	125	255	<span>⋮</span>

## VLAN Status

Use this page to view information about the IGMP snooping querier status for all VLANs that have the snooping querier enabled.

VLAN Configuration		VLAN Status			
<b>IGMP Snooping Querier VLAN Status</b>					
Filter By <input type="text"/>					 OPTIONS
VLAN ID	State	Elected Querier	Version	Max Response Time (Seconds)	
2	Querier	12.0.0.1	2	10.00	



## Spanning Tree Protocol

### Switch

Use this page to configure global **Spanning Tree Protocol (STP)** settings for the switch.

STP is a Layer 2 protocol that decides the best path for LAN traffic when multiple options exist, preventing network loops while guaranteeing redundancy in case of link failure.

For more information about STP, read [Understanding Spanning Tree Protocol \(STP\) & Best Practices](#).

Switch	MST	MST Port	CST	CST Port	Statistics
<h3>Spanning Tree Switch Configuration</h3>					
Enable <span>i</span>					
<input type="checkbox"/>					
Force Protocol Version <span>i</span>					
<input type="radio"/> IEEE802.1w(RSTP) <input checked="" type="radio"/> IEEE802.1s(MSTP)					
Configuration Name <span>i</span>					
<input type="text" value="14:3f:c3:00:0d:d9"/>					
Configuration Revision Level <span>i</span>					
<input type="text" value="0"/>					

### Configurable settings include:

- **Enable** – Enables STP on the switch.
- **Force Protocol Version** – Choose the STP version for the switch to use.
  - **IEEE 802.1w (RSTP)** – Rapid Spanning Tree Protocol (RSTP) behaves like classic STP but can also configure and recognize full-duplex connectivity and ports that are connected to end stations, resulting in rapid transitioning of the port to the Forwarding state and the suppression of Topology Change Notifications.
  - **IEEE 802.1s (MSTP)** – Multiple Spanning Tree Protocol (MSTP) includes all the advantages of RSTP and supports multiple spanning tree instances to efficiently channel VLAN traffic over different interfaces. MSTP is compatible with both RSTP and STP.
- **Configuration Name** – Typically left alone, you can enter the name of the MSTP region. Each switch that participates in the same MSTP region must share the same Configuration Name, Configuration Revision Level, and MST-to-VLAN mappings
- **Configuration Revision Level** – This number must be the same on all switches participating in the MSTP region.

## MST

Use the MST Configuration page to view and configure the Multiple Spanning Tree Instances (MSTIs) on the device.

**Multiple Spanning Tree Protocol (MSTP)** allows the creation of MSTIs based upon a VLAN or groups of VLANs. Configuring MSTIs creates an active topology with a better distribution of network traffic and an increase in available bandwidth when compared to classic STP MST Port.

You can enable **Auto Calculate Port Path Cost** so the path cost from the port to the root bridge is automatically determined by the speed of the interface. If disabled, it must be configured manually.

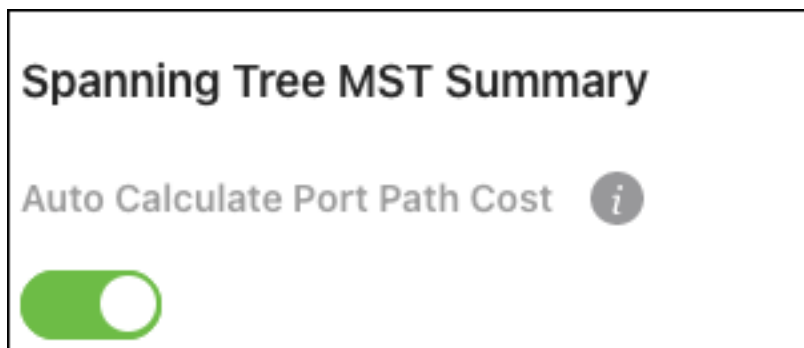

### To add an MST instance:

1. Click the **Options** button (⋮), then **Add**.
2. Enter a number for the **MST ID**.
3. Enter a **Priority** value. This value affects the likelihood that the bridge is selected as the root bridge. A lower value increases the probability that the bridge is selected as the root bridge. For more information, read [Understanding Spanning Tree Protocol \(STP\) & Best Practices](#) for more information.
4. Enter the VLAN ID(s) to map to the MST instance in the **Associated VLANs** field.

5. Click **Add**, then **Apply** at the top of the page.

**Add MST Entry**

MST ID *i*  
1

Priority *i*  
32768

Associated VLANs *i*  
2

Cancel Add

MST instances appear in the table at the bottom of the page.

Switch **MST** MST Port CST CST Port Statistics

**Spanning Tree MST Summary**

Auto Calculate Port Path Cost *i*

Spanning Tree  
Maximum Hops  
20

Filter By

MST ID	Priority	Associated VLANs	Bridge Identifier	Designated Root	Root Path Cost	Root Port	Action
1	32768	1	...	...	0	00:00	...

**Table field descriptions:**

- **MST ID** – Identifies the MST instance.
- **Priority** – The bridge priority for the spanning-tree instance. This value affects the likelihood that the bridge is selected as the root bridge. A lower value increases the probability that the bridge is selected as the root bridge.
- **Associated VLANs** – The number of VLANs that are mapped to the MSTI. This number does not contain any information about the VLAN IDs that are mapped to the instance.
- **Bridge Identifier** – A unique value that is automatically generated based on the bridge priority value of the MSTI and the base MAC address of the bridge. When electing the root bridge for an MST instance, if the bridge priorities for multiple bridges are equal, the bridge with the lowest MAC address is elected as the root bridge.
- **Designated Root** – The bridge identifier of the root bridge for the MST instance. The identifier is made up of the bridge priority and the base MAC address.
- **Root Path Cost** – The path cost to the designated root for this MST instance. Traffic from a connected device to the root bridge takes the least-cost path to the bridge. If the value is 0, the cost is automatically calculated based on port speed.
- **Root Port** – The port on the bridge with the least-cost path to the designated root for the MST instance.

## MST Port

Use this page to view and configure the Multiple Spanning Tree (MST) settings for each interface on the device.

You must configure an MST instance on the MST tab before configuring an interface.

### To configure MST for an interface:

1. Select an **MST ID** from the dropdown.
2. Click the **Options** button () , **Edit**, then select the Interface(s) and click **Edit Selected**. If you only want to edit a single port, click the Action button next to it, then click Edit.
3. Click to select the settings you want to modify, Port Priority or Port Path Cost, then click **Save**.

### Edit MST Port ⓧ

Select options that you want to modify for the selected MST Ports. Anything not modified will not be changed.

MST Port Selected: 1-4

Port Priority i

Port Path Cost i

Port ID:  
Port Forwarding State:  
Port Role:  
Designated Root:  
Designated Cost:  
Designated Bridge:  
Designated Port:

The MST Port Summary table displays information about the currently selected MST ID.

Switch	MST	<u>MST Port</u>	CST	CST Port	Statistics	
<b>Spanning Tree MST Port Summary</b>						
MST ID <input type="text" value="1"/>						
Filter By <input type="text"/>					<input type="button" value="..."/> OPTIONS	
Interface	Name	Port Role	Port Forwarding State	Port Priority	Port Path Cost	Action
0/1	Port 1	Disabled	Discarding	128	0	<input type="button" value="..."/>
0/2	Port 2	Disabled	Discarding	128	0	<input type="button" value="..."/>

**Table field descriptions:**

- **Interface** – The port number.
- **Name** – The name given to the port. Configurable on **Settings > Ports > General > Port Summary** page.
- **Port Role** – The role of the port within the MST is one of the following:
  - **Root** – A port on the non-root bridge that has the least-cost path to the root bridge.
  - **Designated** – A port that has the least-cost path to the root bridge on its segment.
  - **Alternate** – A blocked port that has an alternate path to the root bridge.
  - **Backup** – A blocked port that has a redundant path to the same network segment as another port on the bridge.
  - **Master** – The port on a bridge within an MST instance that links the MST instance to other STP regions.

- **Disabled** – The port is administratively disabled and is not part of the spanning tree.
- **Port Forwarding State** – How traffic is flowing through the port. States include:
  - **Blocking** – Blocks the flow of traffic. When a device is first connected to a port, it enters the blocking state.
  - **Learning** – The port is relaying information from a high-priority BPDU to the other ports on the switch.
  - **Disabled** – Disables the port.
  - **Err-disabled** – Allows STP to block the flow of traffic when it detects a loop, or forward traffic to a port if the connection changes.
- **Port Priority** – The bridge priority for the spanning-tree instance. This value affects the likelihood that the bridge is selected as the root bridge. A lower value increases the probability that the bridge is selected as the root bridge.
- **Port Path Cost** – The path cost from the interface to the MST regional root.

## CST

Use the CST Configuration page to configure the Common Spanning Tree (CST) settings. The settings and information on this page define the device within the spanning tree topology that connects all STP/RSTP bridges and MSTP regions.

### Configurable settings include:

- **Bridge Priority** – This value affects the likelihood that the bridge is selected as the root bridge. A lower value increases the probability that the bridge is selected as the root bridge. For more information, read [Understanding Spanning Tree Protocol \(STP\) & Best Practices](#) for more information.
- **Bridge Max Age** – The amount of time a bridge waits before implementing a topological change.
- **Bridge Forward Delay** – The amount of time a bridge remains in a listening and learning state before forwarding packets.



- **Spanning Tree Maximum Hops** – The maximum number of hops a Bridge Protocol Data Unit (BPDU) is allowed to traverse within the spanning tree region before it is discarded.
- **BPDU Guard** – When enabled, this feature can disable edge ports that receive BPDU packets. This prevents a new device from entering the existing STP topology, so devices that were originally not a part of STP are not allowed to influence the STP topology.  
Pro Tip: Do not enable this feature unless there's a specific use case for it.
- **Spanning Tree TX Hold Count** – The maximum number of BPDUs that a bridge is allowed to send within a hello time window.
- **Auto Calculate Port Path Cost** – The path cost from the port to the root bridge is automatically determined by the speed of the interface. If disabled, it must be configured manually.

The bottom of the page provides general CST information.

Bridge Hello Time:	2
Bridge Identifier:	00:00:14:3F:C3:00:0D:D9
Time Since Topology Change:	0d:00:00:00
Topology Change Count:	0
Designated Root:	0:0:0:0:0:0:0:0
Root Path Cost:	0
Root Port:	00:00
Max Age:	20
Forward Delay:	15
Hold Time:	6
CST Regional Root:	00:00:14:3F:C3:00:0D:D9

## CST Port

Use the CST Port page to view and configure the Common Spanning Tree (CST) settings for each port on the switch.

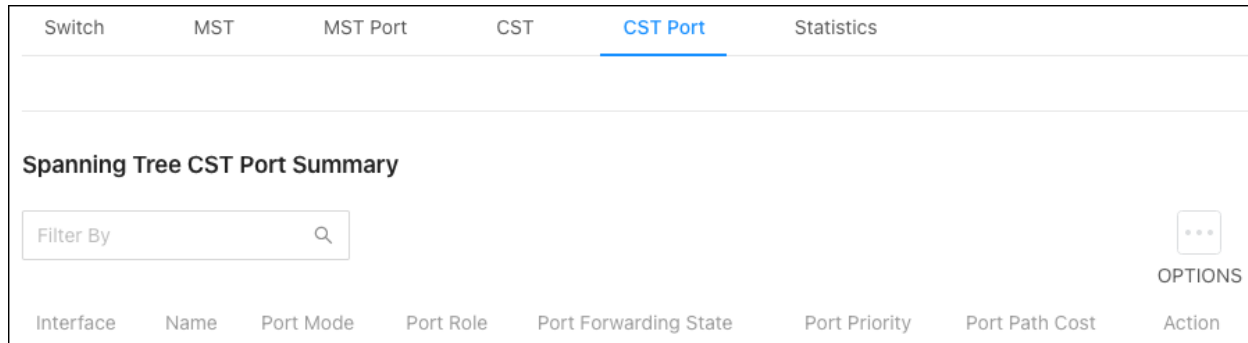

Interface	Name	Port Mode	Port Role	Port Forwarding State	Port Priority	Port Path Cost	Action
-----------	------	-----------	-----------	-----------------------	---------------	----------------	--------

### Table field descriptions:

- **Interface** — The port number.
- **Name** — The name given to the port. Configurable on **Settings > Ports > General > Port Summary** page.
- **Port Mode** — The role of the port within the CST, which is one of the following:
  - **Root** — A port on the non-root bridge that has the least-cost path to the root bridge.
  - **Designated** — A port that has the least-cost path to the root bridge on its segment.
  - **Alternate** — A blocked port that has an alternate path to the root bridge.
  - **Backup** — A blocked port that has a redundant path to the same network segment as another port on the bridge.
  - **Master** — The port on a bridge within an MST instance that links the MST instance to other STP regions.
  - **Disabled** — The port is administratively disabled and is not part of the spanning.
- **Port Forwarding State** — How traffic is flowing through the port. States include:

- **Blocking** – Blocks the flow of traffic. When a device is first connected to a port, it enters the blocking state.
- **Learning** – The port is relaying information from a high-priority BPDU to the other ports on the switch.
- **Disabled** – Disables the port.
- **Err-disabled** – Allows STP to block the flow of traffic when it detects a loop, or forward traffic to a port if the connection changes.
- **Port Priority** – The port’s location in the network topology and how well it’s situated to pass traffic.
- **Port Path Cost** – The path cost from the interface to the CST regional root.
- **Action** – Whether the port is permitting or denying traffic.

Click the **Action** button to edit a port’s priority.

### Statistics

Use this page to view how many BPDUs have been transmitted and received on individual ports. Click the **Options** (...) button, then **Refresh** to get the latest statistics.

Switch	MST	MST Port	CST	CST Port	Statistics
<b>Spanning Tree Statistics</b>					
Filter By <input type="text"/>					...
					OPTIONS
Interface	Name	BPDUs Rx	BPDUs Tx		
0/1	Port 1	0	0		
0/2	Port 2	0	0		

## Multicast Forwarding Database

### Summary

Use this page for a summary of the multicast data collected by the switch. Click **Options** (⋮), then **Refresh** to get the latest information.

Summary	IGMP Snooping	Group Address	Statistics		
<b>Multicast Forwarding Database Summary</b>					
Filter By <input type="text"/>			⋮ OPTIONS		
VLAN ID	MAC Address	Component	Type	Interface(s)	Forwarding Interface(s)
1	01:00:5e:7f:ff:fa	IGMP Snooping	Dynamic	0/1	0/1
2	01:00:5e:7f:ff:fa	IGMP Snooping	Dynamic	0/1	0/1

### IGMP Snooping

Use this table to gather information about the IGMP snooping traffic collected by the switch.

Click **Options** (⋮), then **Refresh** to get the latest information or click **Clear** to reset the table.

Summary	IGMP Snooping	Group Address	Statistics
<b>Multicast Forwarding Database IGMP Snooping Table</b>			
Filter By <input type="text"/>			⋮ OPTIONS
VLAN ID	MAC Address	Type	Interface(s)
1	01:00:5e:7f:ff:fa	Dynamic	0/1
2	01:00:5e:7f:ff:fa	Dynamic	0/1

**Note:** Not all multicast traffic is handled by IGMP snooping. Read [Understanding Spanning Tree Protocol \(STP\) & Best Practices for](#) more information.

## Group Address

Use this table to see the multicast group addresses the switch has recorded. Click **Options** (⋮), then **Refresh** to get the latest information.

Summary	IGMP Snooping	Group Address	Statistics
<b>IGMP Snooping Group Addresses</b>			
Filter By <input type="text"/>			⋮ OPTIONS
VLAN ID	Group Address	Interfaces List	
1	239.255.255.250	0/1	
2	239.255.255.250	0/1	

## Statistics

Use this page to view multicast statistics the switch has gathered.

Summary	IGMP Snooping	Group Address	Statistics
<b>Multicast Forwarding Database Statistics</b>			
MFDB Max Table Entries:		1000	
MFDB Most Entries Since Last Reset:		0	
MFDB Current Entries:		2	

# Neighbors

## LLDP

### Global

Use this page to configure global **Link Layer Discovery Protocol (LLDP)** settings for the switch. LLDP is a generic protocol used to advertise the device's capabilities to other devices on the network.

Global	Interface Summary	Local Devices	Remote Devices	Statistics
<b>LLDP Global Configuration</b>				
Transmit Interval (Seconds) ⓘ				
<input type="text" value="30"/>				
Transmit Hold Multiplier ⓘ				
<input type="text" value="4"/>				
Re-Initialization Delay (Seconds) ⓘ				
<input type="text" value="2"/>				
Notification Interval (Seconds) ⓘ				
<input type="text" value="30"/>				

### Configurable settings include:

- **Transmit Interval (Seconds)** – The number of seconds between LLDP transmissions.
- **Transmit Hold Multiplier** – Multiply the value entered with the Transmit interval to determine the Time to Live (TTL) value that the switch advertises.

The TTL value is the number of network hops that a packet can take before it's discarded by the router.

- **Re-Initialization Delay (Seconds)** – The number of seconds to wait before attempting to reinitialize LLDP on a port after the port’s LLDP operating mode changes.
- **Notification Interval (Seconds)** – The minimum number of seconds to wait between transmissions of SNMP trap notifications on the switch.

## Interface Summary

Use this page to configure LLDP settings on individual ports.

Global <u>Interface Summary</u> Local Devices Remote Devices Statistics									
<b>LLDP Interface Summary</b>									
Filter By <input type="text"/>									...
									OPTIONS
Interface	Name	Port ID Subtype	Link Status	Transmit	Receive	Notification	Optional TLV (s)	Transmit Management Information	Action
0/1	Port 1	MAC Address	Up	Enabled	Enabled	Disabled		No	...
0/2	Port 2	MAC Address	Down	Enabled	Enabled	Disabled		No	...

### To configure LLDP on a port(s):

1. Click the **Options** (⋮) button to edit multiple ports, or the **Action** button to edit an individual port.
2. For **Port ID Subtype**, select if you’d like LLDP to advertise the port’s **MAC address** or the **Interface Name**.
3. Enable or disable if the port can Transmit or Receive LLDP advertisements.
4. Toggle **Notification Enable** on to let the port send LLDP notifications.
5. Select a **Notification Type**. When Notification Enable is on, MIS is the only option.

6. Enable **Transmit Management Information** so other remote management devices on the network can locate the switch.
7. Select **Optional TLV(s)** for the switch to advertise.
8. Click **Save**, then **Apply** at the top of the page.

**Edit LLDP Interface Configuration** ⓧ

LLDP Interface Configuration Selected: 1

Port ID Subtype i

MAC Address  Interface Name 2

Transmit i

3

Receive i

Notification Enable i

4

Notification Type i

MIS  Remote  Both 5

Transmit Management Information i

6

Optional TLV(s) i 7

0 - Port Description  1 - System Name  
 2 - System Description  3 - System Capabilities

8

## Local Devices

Use this page to gather LLDP information about the switchports.





Global    Interface Summary    **Local Devices**    Remote Devices    Statistics

---

**LLDP Local Device Summary**

Filter By  

 **OPTIONS**

Interface	Name	Port ID	Action
0/1	Port 1	14:3F:C3: [REDACTED]	
0/2	Port 2	14:3F:C3: [REDACTED]	

Click the **Actions** button to get more information about the port.

## Local Devices ✕

---

**Local Devices Selected: 1**

Interface: 0/1  
 Name: Port 1  
 Chassis ID Subtype: Mac Address  
 Chassis ID: 14:3F:C3: [REDACTED]  
 Port ID Subtype: Mac Address  
 Port ID: 14:3F:C3: [REDACTED]  
 System Name: AN-620-SW-R-8-POE-000DD9  
 System Description: Araknis 620 8 Port PoE Switch, 1.00.10.000000  
 System Capabilities Supported: Bridge, Router  
 System Capabilities Enabled: Bridge, Router  
 Management Address:  
 Management Address Type:

Close

### Remote Devices

Use this page to view LLDP information collected by the device connected to the switch's port.

Global	Interface Summary	Local Devices	Remote Devices	Statistics		
<b>LLDP Remote Device Summary</b>						
Filter By <input type="text"/>				...		
				OPTIONS		
Interface	Name	Remote ID	Chassis ID	Port ID	System Name	Action
0/1	Port 1	1	D4:6A:91: [REDACTED]	gi3	AN-210-SW-16-POE	...

Click the **Actions** button to get more information about the connected device.

## Remote Devices ⓧ

---

**Remote Devices Selected: 1**

Remote ID: 1

Chassis ID Subtype: Mac Address

Chassis ID: D4:6A:91: [REDACTED]

Port ID Subtype: Local

Port ID: gi3

System Name: AN-210-SW-16-POE

System Description: Araknis 210 16 Port PoE

Port Description: AN-620 Switch

System Capabilities Supported: Bridge

System Capabilities Enabled: Bridge

Time To Live: 120

Close

## Statistics

Use this page to view LLDP counts. Click **Options** (⋮), then **Refresh** to get the most up-to-date information. Click **Clear** to reset the table.

Interface	Name	Transmit Total	Receive Total	Discards	errors	Ageouts	TLV Discards	TLV Unknowns	TLV MED
0/1	Port 1	118275	23615	0	0	0	23615	0	0

## LLDP-MED

### Global

LLDP-MED is an extension of LLDP. MED stands for Media Endpoint Device and is typically used for voice over IP (VoIP).

LLDP and LLDP-MED cannot operate simultaneously. If a device receives LLDP packets it cannot send LLDP-MED packets until it receives LLDP-MED packets. Likewise, for LLDP.

Use this page to enter a value for the **Fast Start Repeat Count**. This is the number of LLDP-MED Protocol Data Units (PDUs) that can be transmitted.

Click **Apply** to save changes.

Global    Interface Summary    Local Devices    Remote Devices

---

## LLDP-MED Global Configuration

Fast Start Repeat Count 

Device Class: Network Connectivity

### Interface Summary

Use this page to configure LLDP-MED settings on individual ports.



Global    **Interface Summary**    Local Devices    Remote Devices

---

### LLDP-MED Interface Summary

Filter By  

 **OPTIONS**

Interface	Name	Link Status	MED Status	Transmit TLVs	Action
0/1	Port 1	Up	Disabled		
0/2	Port 2	Down	Disabled		

### To configure LLDP-MED on a port(s):

1. Click the **Options** () button to edit multiple ports, or the **Action** button to edit an individual port.
2. Enable or disable **LLDP-MED** on the port.

3. Select optional **Transmit TLVs** to advertise.
4. Click **Save**, then **Apply** at the top of the page.

**Edit LLDP-MED Interface**

LLDP-MED Interface Selected: 1

LLDP-MED Mode ⓘ

2

Transmit TLVs ⓘ

0 - Capabilities  3 - Extended PSE 3

Cancel Save 4

## Local Devices

Use this page to gather LLDP-MED information about the switchports.

Global	Interface Summary	Local Devices	Remote Devices
<b>LLDP-MED Local Devices Summary</b>			
Filter By <input type="text"/>			⋮ OPTIONS
Interface	Port ID	Action	
0/1	14:3F:C3:00:0D:DA	⋮	

Click the **Actions** button to get more information about the port.

**LLDP-MED Local Devices Information Selected: 1**

Interface

0/1

---

**Location Information**

Sub Type	Information
Coordinate Based	
Civic Address	
ELIN	

---

**Extended POE**

Items	Value
Device Type	PSE

---

**Extended POE PSE**

Items	Value
Available	60.0 Watts
Source	Primary
Priority	Low

## Remote Devices

Use this page to view LLDP-MED information collected by the device connected to the switch's port.

Global	Interface Summary	Local Devices	<u>Remote Devices</u>	
<b>LLDP-MED Remote Devices Summary</b>				
Filter By <input type="text"/>			<input type="button" value="..."/> OPTIONS	
Interface	Name	Remote ID	Device Class	Action
0/1	Port 1	1	Not Defined	<input type="button" value="..."/>

Click the **Actions** button to get more information about the port.

**LLDP-MED Remote Device Information Selected: 1**

Interface

0/1

Remote ID

1

**Capability Information**

Items Value

Supported Capabilities

Enabled Capabilities

Device Class Not Defined

**Network Policy Information**

Media Application Type	VLAN ID	Priority	DSCP	Unknown Bit Status	Tagged Bit Status
------------------------	---------	----------	------	--------------------	-------------------

**Inventory Information**

Items Value

Hardware Revision

Firmware Revision

Software Revision

Serial Number

Manufacturer Name

Model Name

Asset ID

**Location Information**

Sub Type Information

Coordinate Based

Civic Address

ELIN

**Extended POE**

Items Value

Device Type

**Extended POE PD**

## MAC Address Table

Use the page to see which MAC addresses the switch has recorded traffic from on a port(s) and which VLAN they're a member of. Use the **Options** (...) button to refresh the page, or to select how many rows to display.

**Pro Tip:** Use the Filter By field to search for MAC addresses.

MAC Address Table

---

MAC Address Table

Filter By  

 OPTIONS

VLAN ID	MAC Address	Interface	Name	Interface Index	Status
1	XXXXXXXXXX	0/1	Port 1	1	Learnt
1	XXXXXXXXXX	0/1	Port 1	1	Learnt
1	XXXXXXXXXX	0/1	Port 1	1	Learnt
1	XXXXXXXXXX	0/1	Port 1	1	Learnt
1	XXXXXXXXXX	0/1	Port 1	1	Learnt



## ARP Table

### Summary

The ARP table displays MAC and IP address of devices that have communicated with the switch.

Use the **Options** (⋮) button to refresh the page or clear the table. Use the **Action** button to delete an individual entry.

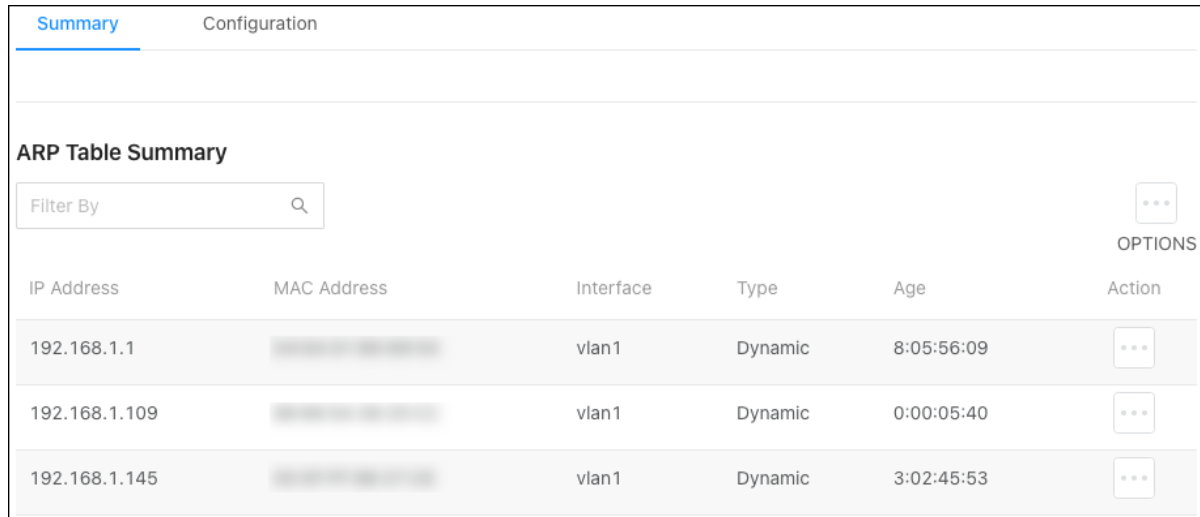

The screenshot shows a web interface with two tabs: "Summary" (selected) and "Configuration". Below the tabs is a search bar labeled "Filter By" with a magnifying glass icon. To the right of the search bar is an "OPTIONS" button with a three-dot menu icon. Below this is a table with the following columns: "IP Address", "MAC Address", "Interface", "Type", "Age", and "Action". The table contains three rows of data:

IP Address	MAC Address	Interface	Type	Age	Action
192.168.1.1	████████████████	vlan1	Dynamic	8:05:56:09	⋮
192.168.1.109	████████████████	vlan1	Dynamic	0:00:05:40	⋮
192.168.1.145	████████████████	vlan1	Dynamic	3:02:45:53	⋮

### Table fields include:

- **IP Address** – The IP address of the device.
- **MAC Address** – The MAC address of the device.
- **Interface** – The VLAN ID associated with the device.
- **Type** – The type of IP address the device is broadcasting. Dynamic or static. Devices with MAC reservations appear as dynamic.
- **Age** – How long the switch has seen the connection to the device. (Days:Hours:Minutes:Seconds)

## Configuration

Use this page to configure the ARP Table's settings.

Summary [Configuration](#)

---

### ARP Table Configuration

Age Time (Seconds) ⓘ

Retries ⓘ

Dynamic Renew ⓘ

Response Time: 1  
Cache Size: 3  
Cache Size Max: 1000  
Cache Size Min: 0

### Configurable settings include:

- **Age Time (Seconds)** – The amount of time that a dynamic ARP entry remains in the ARP table before aging out.
- **Retries** – The number of attempts the switch will send an ARP request if an ARP response isn't received. This number includes the initial ARP request.
- **Dynamic Renew** – Enable to allow the switch to automatically renew dynamic ARP entries when they age out.

# Routing

## *Router*

### Configuration

Use this page to act configure the switch as a layer 3 device by routing packets between interfaces configured for IP routing.

#### **Configurable options include:**

- **Enable** — Enables the routing feature globally on the switch.
- **ICMP Echo Replies** — Enable to allow the device to send ICMP Echo Reply messages in response to ICMP Echo Request (ping) messages it receives.
- **ICMP Redirects** — Enable to allow the device to send ICMP Redirect messages to hosts. An ICMP Redirect message notifies a host when a better route to a particular destination is available on the network segment.
- **Forward Net Directed Broadcasts** — A network-directed broadcast is a broadcast directed to a specific subnet. Enable this feature to forward network-directed broadcasts. If disabled, network-directed broadcasts are dropped.
- **ICMP Rate Limit Interval** — Enter the maximum burst interval for ICMP error messages transmitted by the switch. The rate limit for ICMP error messages is configured as a token bucket. The ICMP Rate Limit Interval specifies how often the token bucket is initialized with tokens of the size configured in the ICMP Rate Limit Burst Size field.
- **ICMP Rate Limit Burst Size** — Enter the number of ICMP error messages that can be sent during the burst interval configured in the ICMP Rate Limit Interval field.
- **Static Route Preference** — The default distance (preference) for static routes. Lower route-distance values are preferred when determining the best route. This value is used when using the CLI to configure a static route and no preference is specified. Changing the Static Route Preference does not update the preference of

existing static routes.

- **Global Default Gateway** – The gateway IP address that the switch uses. If the destination IP address in a packet does not match any routes in the routing table, the packet is sent to the default gateway. The gateway specified in this field is preferable to a default gateway learned from a DHCP server.

## Interface Configuration

Use this page to enable and configure routing on specific interfaces. Each interface is disabled by default.

Use the **Options** (⋮) button to add a VLAN, or the **Action** button in an interface row to configure routing features.

Each row has a toggle to quickly enable or disable the interface.

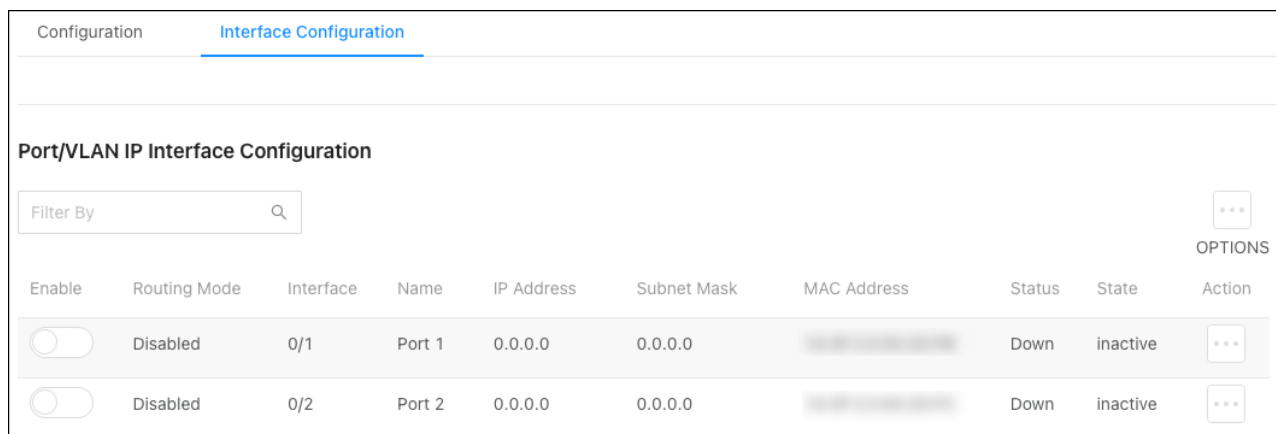

The screenshot shows a web interface for configuring network interfaces. At the top, there are tabs for 'Configuration' and 'Interface Configuration'. Below the tabs is a section titled 'Port/VLAN IP Interface Configuration' with a search filter. The main content is a table with columns for 'Enable', 'Routing Mode', 'Interface', 'Name', 'IP Address', 'Subnet Mask', 'MAC Address', 'Status', 'State', and 'Action'. Two rows are visible, representing Port 1 and Port 2, both currently disabled and inactive.

Enable	Routing Mode	Interface	Name	IP Address	Subnet Mask	MAC Address	Status	State	Action
<input type="checkbox"/>	Disabled	0/1	Port 1	0.0.0.0	0.0.0.0	XXXXXXXXXX	Down	inactive	⋮
<input type="checkbox"/>	Disabled	0/2	Port 2	0.0.0.0	0.0.0.0	XXXXXXXXXX	Down	inactive	⋮

### Configurable options include:

- **Type** – The type of interface being configured.
- **Interface** – The type of interface being configured. VLAN or Interface (port).
- **Routing Mode** – Enable to use the routing feature on the interface.
- **Enable** – Enables the port to forward traffic.
- **IP Address Configuration Method** – Select the method that the interfaces obtain an IP Address. Options include:

- **None** — The interface does not receive an IP address.
- **Manual** — Select this option to use the fields below to configure the interface's IP address and subnet mask.
- **DHCP** —The interface automatically obtains an IP address from the DHCP server.
- **IP Address** — Only available when the interface IP Address Configuration Method is set to Manual.
- **Subnet Mask** — Only available when the interface IP Address Configuration Method is set to Manual.
- **Bandwidth** — Configure the bandwidth on the interface. This setting communicates the speed of the interface to higher-level protocols.
- **Encapsulation Type** — The link layer encapsulation type for packets transmitted from the interface. **Ethernet** is the only option.
- **Destination Unreachables** — When enabled, the interface is allowed to send ICMP Destination Unreachable message to a host if the intended destination cannot be reached. If this option is clear, the interface does not send ICMP Destination Unreachable messages.
- **ICMP Redirects** — When enabled, the interface is allowed to send ICMP Redirect messages to notify a host when a better route to a particular destination is available on the network segment. ICMP Redirects must be enabled both globally, and on the interface, to work.

## ***IP Routing***

### **Route Table**

Use this table to view routes on the switch. Use the **Options** () button to refresh the page.

Route Table Summary

Filter By



OPTIONS

Network Address	Subnet Mask	Protocol	Next Hop IP Address	Next Hop Interface	Best Route
0.0.0.0	0.0.0.0	Default	192.168.1.1	vlan1	Best
192.168.1.0	255.255.255.0	Local	0.0.0.0	vlan1	Best

## Configured Routes

Use this page to view and configure routes on the switch. Click the **Options** (⋮) button to add a new route.

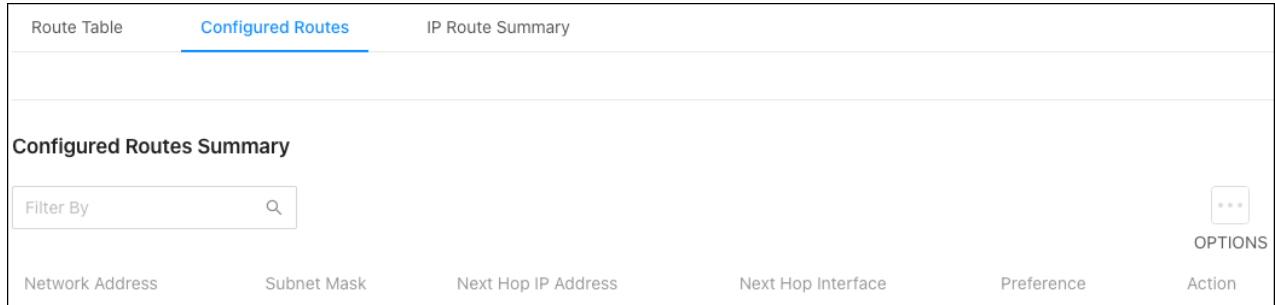

### Configurable settings include:

- **Route Type** — Select one of the following routes to configure:
  - **Default** — The route the device uses to send a packet if the routing table does not contain a longer matching prefix for the packet's destination. The routing table can contain only one default route.
  - **Static** — A manually added route.
  - **Static Reject** — A route where packets that match the route are discarded instead of forwarded. The device might send an ICMP Destination Unreachable message.
- **Network Address** — Enter the IP route prefix for the destination network. This IP address must contain only the network portion of the address and not the host bits. When adding a default route, this field must be 0.0.0.0.
- **Subnet Mask** — Enter the IP subnet mask (also known as the network mask or netmask) associated with the network address. The subnet mask defines which portion of an IP address belongs to the network prefix, and which portion belongs to the host identifier. When adding a default route, this field must be 0.0.0.0.

- **Next Hop IP Address** – Enter the outgoing router IP address to use when forwarding traffic to the next router (if any) in the path toward the destination. The next router is always an adjacent neighbor or the IP address of the local interface for a directly attached network. When adding a static reject route, this field must be 0.0.0.0 because the packets are dropped rather than forwarded.
- **Preference** – Enter a preference value for the route. A lower preference value is a more preferred route. When the routing table has more than one route to the same network, the device selects the route with the lowest route preference.

### IP Route Summary

This page displays a summary of the IP routes and route table counters the switch has collected.

Route Table	Configured Routes	IP Route Summary
<b>IP Route Summary</b>		
<b>Route Types</b>		
Connected Routes:	1	
Static Routes:	0	
Total Routes:	1	



# QoS

## ACL Rules

### Summary

Use this page to configure **Access Command List (ACL)** Rules. Access Control Lists (ACLs) make sure that only authorized users have access to specific resources and block unwanted attempts by filtering packets based on rules. ACLs are used to control traffic flow, restrict the contents of routing updates, decide which types of traffic to block or forward, and provide network security.

#### To add an ACL rule:

1. Click **Options** (⋮), then **Add**.
2. Select an **ACL Type**:
  - **IPv4 Standard** - Match criteria is based on the source address of IPv4 packets.
  - **IPv4 Extended** - Match criteria can be based on the source and destination addresses, source and destination Layer 4 ports, and protocol type of IPv4 packets. The ACL identifier can be an alphanumeric name instead of a number, known as IPv4 Named in other switches.
3. Enter a number for the **ACL ID**.
4. Click **Add**, then **Apply** at the top of the page.

The screenshot shows a dialog box titled "Add ACL Summary" with a close button in the top right corner. Below the title bar, there are two input fields. The first is labeled "ACL Type" with an information icon (i) and a dropdown menu currently showing "IPv4 Standard"; a red circle with the number "2" is positioned to the right of the dropdown. The second is labeled "ACL ID" with an information icon (i) and an empty text input field; a red circle with the number "3" is positioned to the right of the field. At the bottom of the dialog, there are two buttons: "Cancel" on the left and "Add" on the right, which is highlighted in green; a red circle with the number "4" is positioned to the left of the "Add" button.

## Interfaces

Use this page to add an ACL rule to a port(s).

### To add an ACL rule to a port:

1. Click **Options** (⋮), then **Add**.
2. Select the **Interface** (port) to apply the ACL rule to.
3. Select **Inbound** as the **Direction**, if the packets should be checked against the ACL rules when the port(s) receives it. Do not select Inbound if the packets should be checked when the packets are exiting the port(s).
4. Select the **ACL Identifier** of the ACL rule to apply to the port(s).
5. Click **Add**, then **Apply** at the top of the page.

The screenshot shows a dialog box titled "Add ACL Interface Configuration". It has a close button in the top right corner. The dialog is divided into three sections: "Interface" with a dropdown menu showing "0/4" and a red circle "2" next to it; "Direction" with radio buttons for "Inbound" (selected) and a red circle "3" next to it; and "ACL Identifier" with a dropdown menu showing "1" and a red circle "4" next to it. At the bottom, there are two buttons: "Cancel" and "Add" (highlighted in green) with a red circle "5" next to it.

## ACL Configuration

### IPv4 Standard

Use this page to configure IPv4 Standard ACLs. Click the **Options** (⋮) button to edit multiple ACLs or the **Actions** button to edit a single ACL.

IPv4 Standard		IPv4 Extended			
<b>ACL IPv4 Standard Configuration</b>					
Filter By <input type="text"/>					...
OPTIONS					
ACL ID	Perform Action	Direction	Status	Remark	Action
1	Permit	Inbound	active		...

### Configurable settings include:

- **Perform Action** – The action to take when a packet or frame matches the criteria in the rule:
  - **Permit** – The packet or frame is forwarded.
  - **Deny** – The packet or frame is dropped.
  - **Redirect** – Redirect to interface.
  - **Copy-to-cpu** - Configures the copying of protocol control packets to control plane CPU.
  - **Drop Copy-to-cpu** - Copies TCP protocol control packets to control plane CPU without switching packets.
- **Redirect** – The port(s) the ACL redirects to.
- **Source IP Address** – The source port IP address in the packet and source IP mask (in the second field) to compare to the IP address in a packet header or string 'ANY' (default).
- **Source IP Mask** – An IP Mask for the source or string 'ANY' (default).
- **Destination IP Address** – The destination port IP address in the packet and destination IP mask (in the second field) to compare to the IP address in a packet header or string 'ANY' (default).
- **Destination IP Mask** – An IP Mask for the destination or string 'ANY' (default).

- **Remark** – Use remarks as a keyword to make ACLs easier to understand in network scans. Accepts alpha-numeric and special characters (-, \_, and space). The remark can be up to 100 characters and is case-sensitive.

## IPv4 Extended

Use this page to configure IPv4 Extended ACLs. Click the **Options** (⋮) button to edit multiple ACLs or the **Actions** button to edit a single ACL.

IPv4 Standard		IPv4 Extended		
<b>ACL IPv4 Extended Configuration</b>				
Filter By <input type="text"/>				⋮ OPTIONS
ACL ID	Perform Action	Direction	Status	Action
2000	Permit	Inbound	active	⋮

### Configurable settings include:

- **Perform Action** – The action to take when a packet or frame matches the criteria in the rule:
  - **Permit** – The packet or frame is forwarded.
  - **Deny** – The packet or frame is dropped.
  - **Redirect** – Redirect to interface.
  - **Copy-to-cpu** - Configures the copying of protocol control packets to control plane CPU.
  - **Drop Copy-to-cpu** - Copies TCP protocol control packets to control plane CPU without switching packets.
- **Redirect** – The port(s) the ACL redirects to.

- **Source IP Address** – The source port IP address in the packet and source IP mask (in the second field) to compare to the IP address in a packet header or string 'ANY' (default).
- **Source IP Mask** – An IP Mask for the source or string 'ANY' (default).
- **Destination IP Address** – The destination port IP address in the packet and destination IP mask (in the second field) to compare to the IP address in a packet header or string 'ANY' (default).
- **Protocol** – The IANA-assigned protocol to match within the IP packet.
- **IGMP Type** – The IP ACL rule to match on the specified IGMP type. This option is available only if the protocol is IGMP.
- **ICMP Type** – The IP ACL rule to match on the specified ICMP type. This option is available only if the protocol is ICMP.
- **ICMP Code** – The IP ACL rule to match on the specified ICMP code. This option is available only if the protocol is ICMP.
- **TCP Flags** – The IP ACL rule to match on the TCP flags. This option is available only if the protocol is TCP.
- **IP TOS** – Matches on the Type of Service (TOS) in the IP header.

# System Log

Use the system log page to view and download events recorded by the switch. Click the **Options** (...) button to refresh the page, choose how many rows to display, or download the logs.

**Pro Tip:** Use the Filter by field to quickly find the event types you're looking for. Examples are critical, poe, or vlan.

Severity	Log Time	Component	Detail
info	Oct 7 08:08:13	PoeT	PoE Hw Init Done
info	Oct 7 08:08:13	PoeT	==> mode_pins: 0x2 port_map: 0 hw_ver: 0xe131 sw_ver: 0x13 eeprom: 0 config: 0xa sw_ver_ext: 9
info	Oct 7 08:08:22	CFA	Slot0/1 Link Status [DOWN]
info	Oct 7 08:08:22	CFA	vlan1 Link Status [DOWN]
info	Oct 7 08:08:23	CFA	Slot0/1 Link Status [UP]
info	Oct 7 08:08:24	CFA	vlan1 Link Status [UP]
critical	Oct 7 08:08:32	FM	[FM - MSR] : Configuration restored successfully.

---

# Firmware release notes

## Version 1.1.04

- This is the initial release

---

# Technical Support

For chat and telephone, visit [snpl.co/techsupport](https://snpl.co/techsupport) • Email:

[TechSupport@SnapOne.com](mailto:TechSupport@SnapOne.com). Visit [snpl.co/tc](https://snpl.co/tc) for discussions, instructional videos, news, and more.



---

# Warranty and Legal Notices

Find details of the product's Limited Warranty and other resources such as regulatory notices and patent and safety information, at [snapone.com/legal](https://snapone.com/legal) or request a paper copy from Customer Service at **866.424.4489**.

Copyright© 2024, Snap One, LLC. All rights reserved. Snap One and its respective logos are registered trademarks or trademarks of Snap One, LLC (formerly known as Wirepath Home Systems, LLC), in the United States and/or other countries. 4Store, 4Sight, Control4, Control4 My Home, SnapAV, Araknis Networks, BakPak, Binary, Dragonfly, Episode, Luma, Mockupancy, Nearus, NEEO, Optiview, OvrC, Pakedge, Sense, Strong, Strong Evolve, Strong VersaBox, SunBriteDS, SunBriteTV, Triad, Truvision, Visualint, WattBox, Wirepath, and Wirepath ONE are also registered trademarks or trademarks of Snap One, LLC. Other names and brands may be claimed as the property of their respective owners. Snap One makes no claim that the information contained herein covers all installation scenarios and contingencies, or product use risks. Information within this specification subject to change without notice.

240219

AN-620-SW-A