

WPS-MNT-PA-CNR-WH

Corner Mount for WPS-500-PTZ-A & WPS-750-PTZ-A Cameras

Thank you for purchasing a Wirepath™ Surveillance accessory. This corner mount will allow you to install a Wirepath WPS-500-PTZ-A or a WPS-750-PTZ-A Analog PTZ camera on an outside corner, maximizing surveillance coverage of 2 walls of a building.

Mounting and Use Guidelines

- The corner mount should be installed so that the edges are flush with the wall.
- The mounting surface must be able to support the weight of the corner mount assembly and camera.
- Instructions for using this accessory may be found in the manual included with the Wirepath PTZ camera.

Package Contents

- Corner Bracket
- Junction Box Adapter Plate
- 6mm Allen Key
- Wall Mounting Hardware (5 each, 1 spare):
 - Screws
 - Washers
 - Masonry Anchors
- Adapter Hardware:
 - M8x30 Hex Head Bolts (5, 1 spare)
 - M8x18 Allen Head Screws (5, 1 spare) to attach adapter plate to corner mount
 - M8 Lock Washers (10, 2 spares)
 - M8 Flat Washers (10, 2 spares)

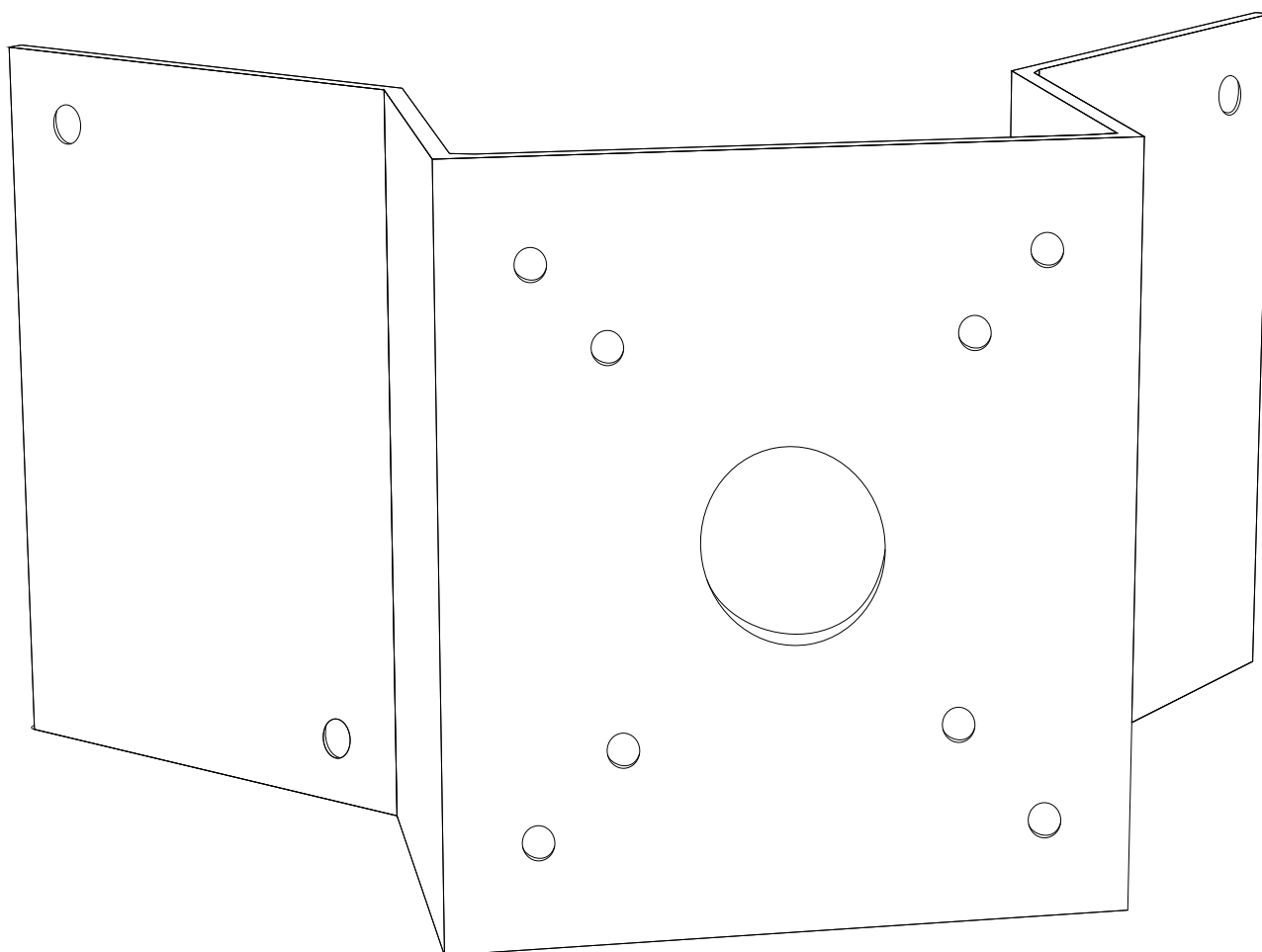

Corner Mount for WPS-500-PTZ-A / WPS-750-PTZ-A Cameras

Dimensions

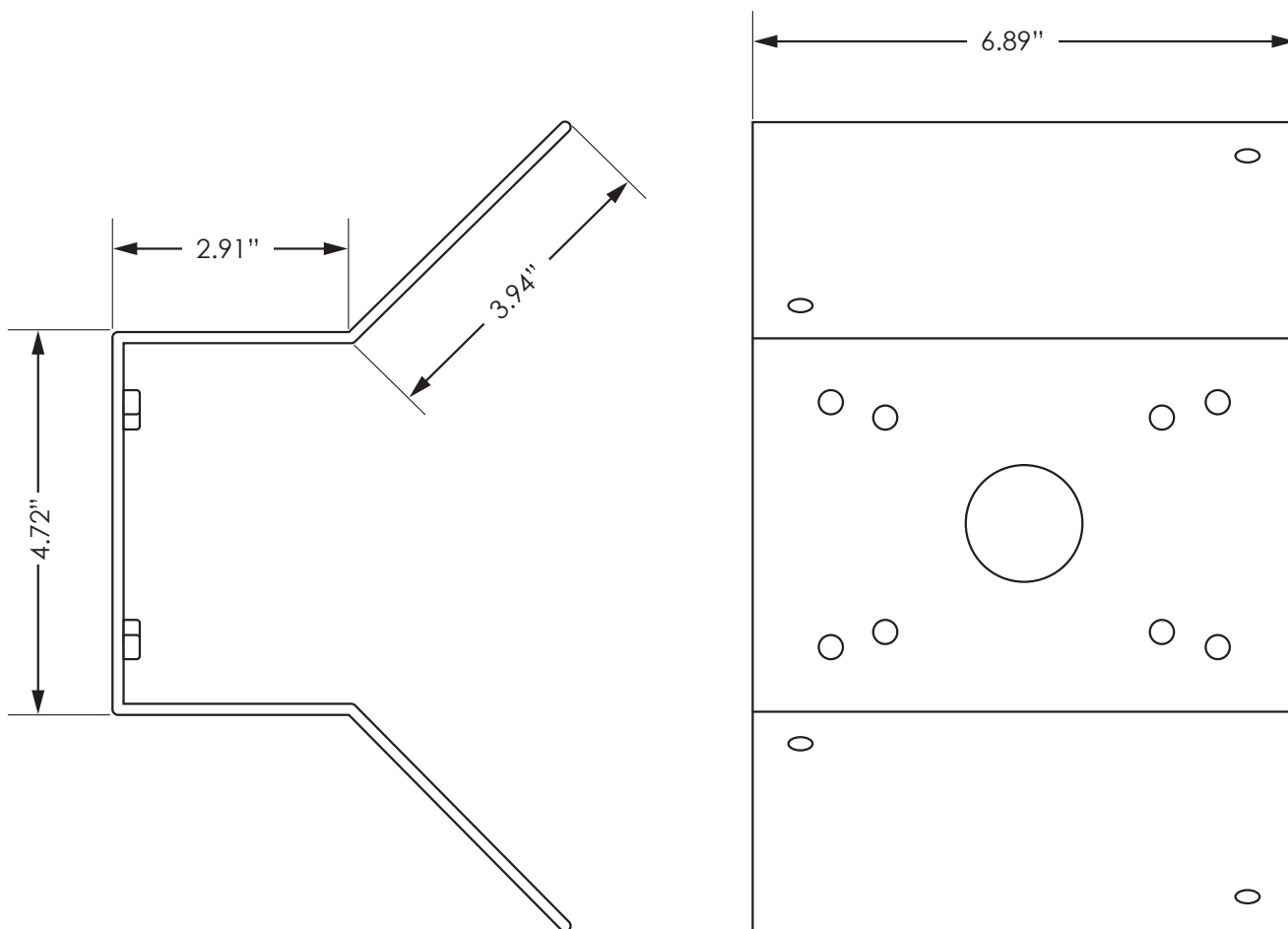

Specifications

Corner Bracket Weight	3.4 lbs.
With Junction Box Adapter Plate	6.2 lbs.
Junction Box Adapter Plate Dimensions	6.75"W x 8.75"H

5-Year Limited Warranty

This accessory has a 5-Year Limited Warranty. The warranty includes parts and labor repairs on all components found to be defective in material or workmanship under normal conditions of use. This warranty shall not apply to products which have been abused, modified, disassembled or improperly installed. Products to be repaired under this warranty must be returned to Wirepath™ Surveillance or a designated service center with prior notification and an assigned return authorization number (RA).

Contacting Tech Support

Phone: 866.838.5052

Email: TechSupport@SnapAV.com