



engineered by
Snap
av

OWNER'S MANUAL

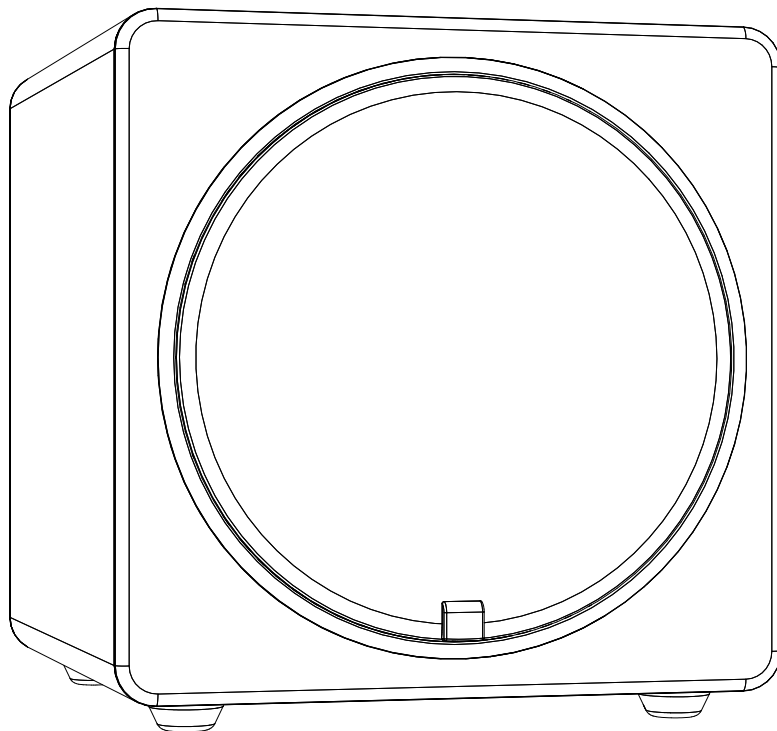

**EVOLUTION SERIES
POWERED SUBWOOFER**

ES-SUB-EVO6-100



Important Safety Instructions



	<p>The lightning flash with arrowhead symbol, within an equilateral triangle, is intended to alert the user to the presence of uninsulated dangerous voltage within the product's enclosure that may be of sufficient magnitude to constitute a risk of electric shock to persons.</p>
	<p>The exclamation point within an equilateral triangle is intended to alert the user to the presence of important operating and maintenance (servicing) instructions in the literature accompanying the appliance.</p>

- 1) Read these instructions.
- 2) Keep these instructions.
- 3) Heed all warnings.
- 4) Follow all instructions.
- 5) Do not use this apparatus near water.
- 6) Clean only with dry cloth.
- 7) Do not block any ventilation openings. Install in accordance with the manufacturer's instructions.
- 8) Do not install near any heat sources such as radiators, heat registers, stoves, or other apparatus (including amplifiers) that produce heat.
- 9) Do not defeat the safety purpose of the polarized or grounding-type plug. A polarized plug has two blades with one wider than the other. A grounding type plug has two blades and a third grounding prong. The wide bladed or the third prong are provided for your safety. If the provided plug does not fit into your outlet, consult an electrician for replacement of the obsolete outlet.
- 10) Protect the power cord from being walked on or pinched particularly at plugs, convenience receptacles, and the point where they exit from the apparatus.
- 11) Only use attachments/accessories specified by the manufacturer.
- 12) Use only with the cart, stand, tripod, bracket, or table specified by the manufacturer, or sold with the apparatus. When a cart is used, use caution when moving the cart/apparatus combination to avoid injury from tip-over. 
- 13) Unplug this apparatus during lightning storms or when unused for long periods of time.
- 14) Refer all servicing to qualified service personnel. Servicing is required when the apparatus has been damaged in any way, such as power-supply cord or plug is damaged, liquid has been spilled or objects have fallen into the apparatus, the apparatus has been exposed to rain or moisture, does not operate normally, or has been dropped.
- 15) The equipment shall be used at maximum 35 degree C ambient temperature.
- 16) Do not open the equipment to reduce the risk of electrical shock. For safety reasons it is only allowed to be opened by qualified service personnel.
- 17) **WARNING:** To reduce the risk of fire or electric shock, do not expose this apparatus to rain or moisture. And the apparatus shall not be exposed to dripping or splashing and that no objects filled with liquids, such as vases, shall be placed on the apparatus.
- 18) The APPLIANCE INLET plug is used as the disconnect device and shall remain readily operable.
- 19) The product shall be used on open bench.

I. Introduction

1. Welcome to Episode®

Episode® is one of the most highly regarded brands of speakers available today. We appreciate your business and we stand committed to providing our customers with the highest degree of quality and service in the industry.

Episode® subwoofers are a superb choice for bass reinforcement of most audio systems. They have been designed with advanced technology components that accurately reproduce low frequencies in all types of music and movies. For optimum system performance, we recommend pairing them with our acclaimed Episode® loudspeakers.

2. Features

World Class Digital Amplifier Technology

These powered subwoofers incorporate the latest digital amplifier technology to maximize performance while generating little heat. In standby mode, the subwoofer consumes less than 0.5 watts, making it one of the "greenest" solutions available.

High-Gloss Cabinet

Attractive furniture-quality cabinet provides the ultimate in rigidity and sound clarity. Gloss black or white can blend into any room.

Tuned System Performance

Offers rear-mounted volume control, low-pass crossover adjustment, and variable (0 or 180 degrees) phase control to ensure optimal system integration, giving a seamless blend for an unbelievable music and movie experience.

Signal-Sensing For Automatic Power Control

There are two power mode options with an Episode® powered subwoofer: Always On and Auto Sense. When Auto Sense is selected, the subwoofer will automatically switch to a power-saving standby mode until an input signal is detected. Power will turn on whenever a minimal amount of signal is detected on the input jacks, and off again when no signal is present for approximately 15 minutes.

Gold-Plated Inputs

Episode® only uses the highest quality inputs available to maximize performance. Stereo inputs are included for easy connections. For home theater use, the left RCA unbalanced input also serves as an LFE (Low Frequency Effects) input for a direct connection from the receiver or processor. For added versatility, there are also gold-plated, five-way binding-post speaker-level inputs.

Flush-Mounted Grille

Gives a smaller profile look which allows the subwoofer to be hidden in the room with ease.

II. Installation and Setup

3. Overview

Proper installation of the Episode® EVO Sub powered subwoofer requires these basic steps:

1. Place the subwoofer in the room. (Page 4)
2. Make connections to the system. (Pages 5 & 6)
3. Fine tune the subwoofer for the best sound quality and operation. (Page 7)

Review the options for each step and use the best method for the application. After installation is complete, test the system thoroughly to ensure reliability and sustained sound quality. If the subwoofer will not function or perform as expected, make sure that installation was completed correctly and check the Troubleshooting Steps before contacting Episode® for assistance.

4. Placing the Subwoofer

Subwoofer placement can have an effect on the performance that you receive. All rooms are different, but the strongest output will likely occur if the subwoofer is placed in a corner of the room on the same wall as the front channel speakers. This is known as the boundary effect and will emphasize certain bass frequencies while canceling others. Some listeners will find this to be the best sounding result, while others may find it "boomy" or muddy. Experiment with the placement options available to you and use the tuning instructions that follow in the "Installation" section of this manual.

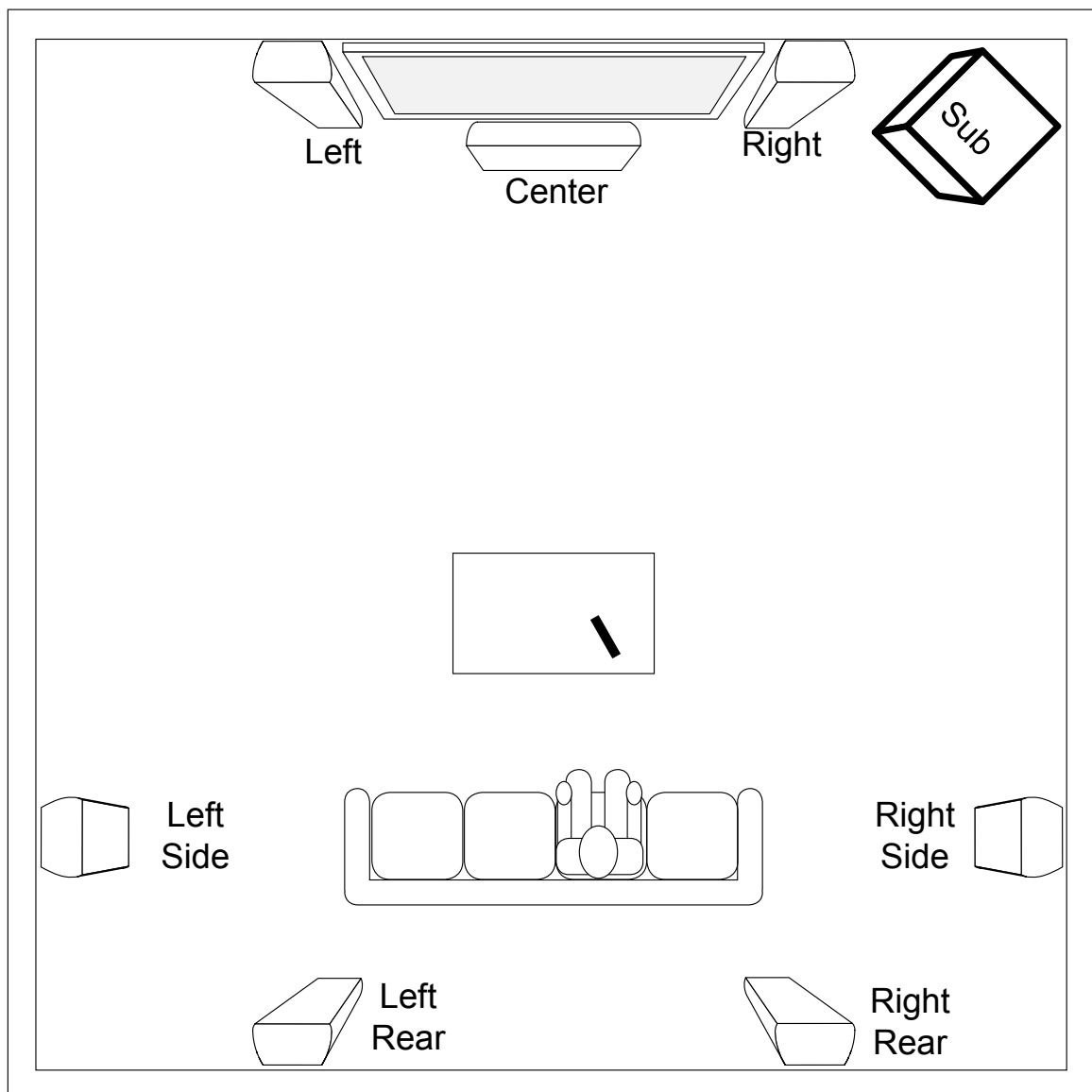

5. Making System Connections

5.1. Wiring Recommendations

- For line-level connections, use high-quality, low impedance RCA cables with adequate shielding and high-quality connectors.
- Use two-conductor loudspeaker cable for high level connections that is appropriate for the installation environment and wire length.

5.2. Audio Connections

To provide signal to the EVO subwoofer, a connection must be made from the audio source or speaker wiring. Most home theater AV receivers and sources supply an "LFE" output for subwoofers that should be used if available. Stereo line or speaker-level inputs from sources or speaker wiring may also be used.

CAUTION! DO NOT connect to both the line and speaker level connections at the same time. Use only line-level connections, or only speaker-level connections.

5.2.1. Line-Level RCA Connections



WARNING! Do not connect to both the low-level RCA and high-level speaker connections. Use only one connection method.

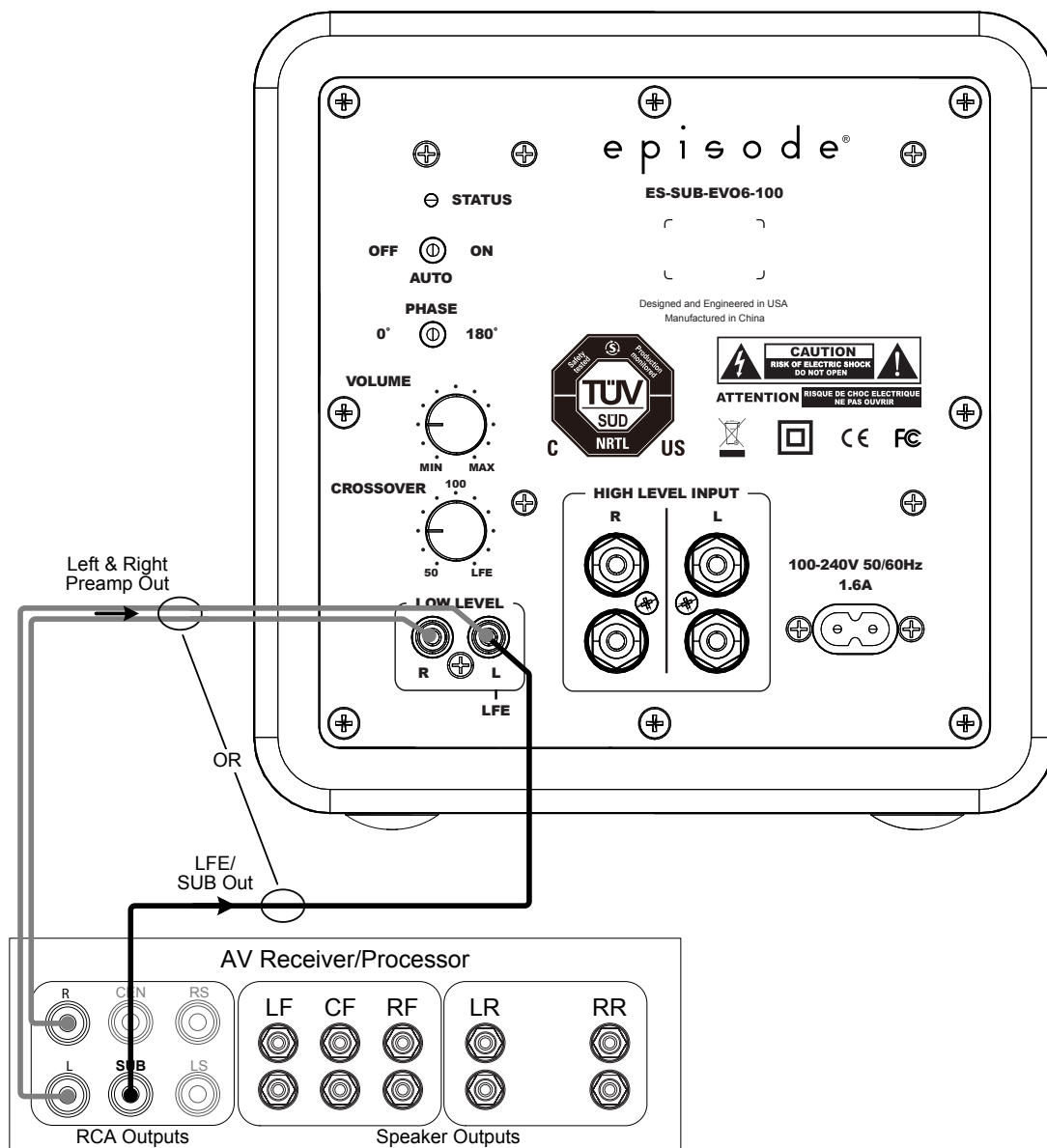

5.2.2. Speaker-Level Connections



WARNING! Do not connect to both the low-level RCA and high-level speaker connections. Use only one connection method.

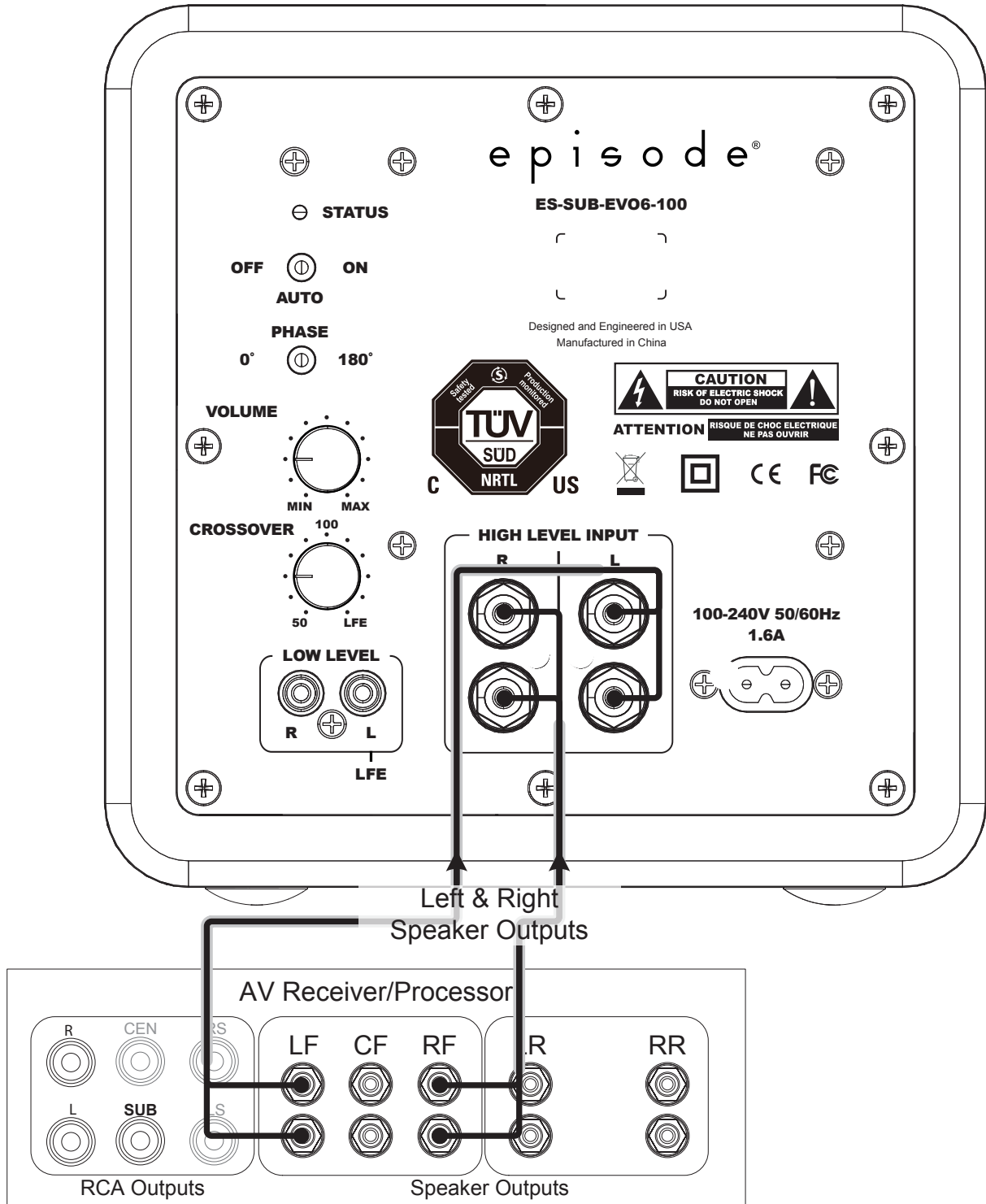

6. Settings and Controls

6.1. Setting the Power Mode

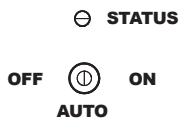

6.1.1. ON Mode

If the subwoofer is set to ON mode, it will always be ready to play. However, undesired noise from interference or connections changing may be heard, and leaving the subwoofer on all the time is not energy efficient. Use the standard ON mode only if needed. Set the power switch to OFF when the amplifier is not in use.

6.1.2. AUTO Mode

Setting the switch to AUTO enables AUTO Sense. The subwoofer turns on and off automatically in response to signal on the inputs. The unit will enter standby mode if no signal is sensed for 15 minutes.

6.2. Fine Tuning Audio and Operation

After making all the connections and calibrating the loudspeakers, set up your Episode® subwoofer using the following steps:

1. Set the MODE switch to the 'ON' position for setup.
2. Plug the subwoofer into an electrical outlet using the included power cord. The status LED will illuminate solid blue when power is present and the subwoofer is on.
3. Set the controls and switches to their initial setup positions:
 - VOLUME dial set to 50%, or 12 o'clock
 - CROSSOVER dial: Set to LFE if LFE input is used; Otherwise, set to match the low-end frequency limit of the satellite speakers in use. See specifications for the speakers installed to determine their low-end limit.
 - PHASE set to 0°
4. Play a movie scene or music track and set the system volume to an average level. Listen to the bass level from your favorite listening position. Adjust the VOLUME control as desired.
5. Continue listening to your favorite music and movie sources using the settings chosen for volume and crossover. Experiment with the PHASE setting until you find the best setting for the installation. Depending on your subwoofer's placement, the bass may sound louder or deeper when the phase has been optimized. In some cases, adjusting phase will make no audible difference.
6. Once calibration is complete, switch the power mode back to 'AUTO' if Auto Sense mode is being used. Wait 15-20 minutes to confirm that AUTO mode is working properly. See Troubleshooting if issues occur.
7. Setup is now complete.

7. Troubleshooting

Episode® speakers are designed to function trouble-free. Most problems that occur are due to simple issues. If you have trouble, please check the list of simple fixes below.

If the problem persists, contact Episode® Technical Support at 1.866.838.5052.

Note: During troubleshooting, temporarily set the MODE switch to 'ON' to ensure signal-sensing power mode is disabled. Ensure that the Status LED is blue with the switch on.

No Sound

- If power mode switch is set to On and LED is Red, call Technical Support.
- Verify that audio is coming from the source selected. Select another source to test, or connect the source directly to the subwoofer input, bypassing any other equipment.
- Ensure that any connected A/V equipment is turned on and connected properly.
- Check cable connections for damage, poor contact, or short circuits.
- Ensure the subwoofer volume is turned up to a reasonable level. The control is located on the back of the unit.

Interference

If undesired noise is heard coming from the subwoofer:

- Check cable connections for damage, poor contact, or short circuits.
- If the issue only occurs when the system is off, check the power mode switch to be sure the subwoofer is set to off, or if using AUTO mode, check that the subwoofer is actually turning off after 15 minutes of inactivity (LED will be Red). If the LED is Blue, the sources may be outputting signal at all times, causing the subwoofer to remain on.
- If the signal cable is installed in the wall, it may be running parallel to high voltage cables. Test the system by running a separate in-room cable. If the issue is resolved, a new cable should be installed with proper clearance from high voltage.
- If the interference occurs when using the Episode® ES-SUB-WIRELESS, bypass the adapter and test with a cable.
- Common sources of interference include Wi-Fi antennas and devices or cordless phones set up too close to the subwoofer or source.

8. Cleaning and Maintenance

- The exterior of the Evolution subwoofer may be cleaned using a soft, lint-free cloth. Use a vacuum cleaner dust brush attachment or lint brush to clean the grille.
- If the subwoofer enclosure is moved often for cleaning or relocation, check each time to ensure that connections are not damaged or loose.

9. Connections and Controls

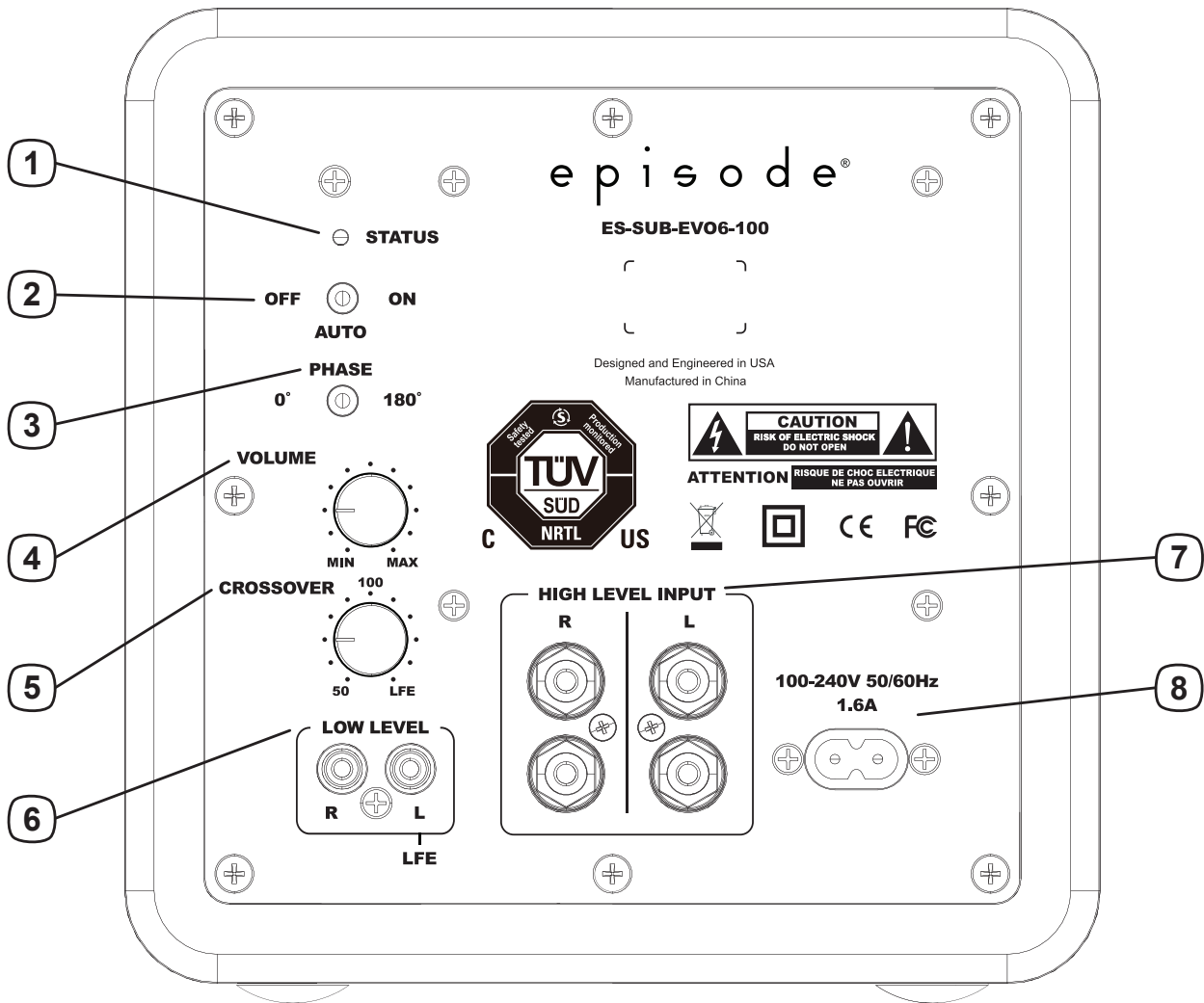

1. **STATUS LED**

Red- Subwoofer is in standby mode, or power mode switch is set to OFF. AC power is present.
 Blue- Subwoofer power mode switch is set to ON, or is set to AUTO and signal is being received.

2. **Power Mode Switch**

3 way toggle switch for setting power mode to OFF, AUTO, or ON.

3. **Phase Switch**

Set the phase of the subwoofer in relation to the listening area.

4. **Volume Knob**

Adjust subwoofer volume.

5. **Crossover Knob**

Adjust the crossover frequency (limits the highest frequency the subwoofer will play).

*Note: Set the crossover knob to "LFE" if the LFE input is used.

6. **LOW LEVEL Inputs (RCA)**

For left/right or LFE connections from audio source. To connect LFE, use the L (left) channel.

7. **HIGH LEVEL INPUT (Speaker Wire Binding Post)**

For left/right connections from speaker cable runs.

8. **Power Cord Inlet**

Connect the included cord for providing power.

10. Specifications

Description	Evolution Sub 6" Black/White (ES-SUB-EVO6-100)
Woofers:	6" Woven Fiberglass Cone, High Temp 1" Voice Coil
Color:	Gloss Black or Gloss White
Power:	100W RMS
Frequency Response (@ -3dB):	36 Hz
Crossover Control:	50 to 200 Hz
Dimensions (inches):	8.0" x 8.1" x 9.1" (W x H x D)
Connectors:	RCA Inputs & Gold Plated 5-Way Binding Posts
Adjustments:	Volume, Crossover Frequency, 0/180° Phase, Auto/On/Off
Weight:	7.5 lbs
Replaceable Fuse:	NA
AC Input Voltage:	100-240V AC
Power Consumption:	1.6A
Optional Accessories:	ES-SUB-WIRELESS, Cables

11. 10/2-Year Limited Warranty

Episode® Subwoofers have a 2-Year Warranty on the amplifier and a 10-Year Warranty on the woofer and box. This warranty includes parts and labor repairs on all components found to be defective in material or workmanship under normal conditions of use. This warranty shall not apply to products which have been abused, modified or disassembled. Products to be repaired under this warranty must be returned to SnapAV or a designated service center with prior notification and an assigned return authorization number (RA).

12. Contacting Technical Support

Phone: (866) 838-5052
 Email: Techsupport@snapav.com

