

MEGAFONÍA / ALTAVOCES / DE TECHO

GAT-80SW

ALTAVOZ DE TECHO SUBWOOFER



ESPECIALMENTE RECOMENDADO EN:



Hostelería



Retail



Hoteles



Todos los sectores

DESCRIPCIÓN:

Altavoz de techo subwoofer con transformador de línea 100 V y rejilla redonda. Refuerzo de graves en instalaciones de línea 100 V.



+ Info:

<https://fonestar.com/GAT-80SW>

CARACTERÍSTICAS TÉCNICAS:

CARACTERÍSTICAS	Altavoz de techo subwoofer con transformador de línea 100 V y rejilla redonda. Refuerzo de graves en instalaciones de línea 100 V.
POTENCIA	90 W máximo, 60 W RMS
ALTAVOCES	1 woofer 8"
RESPUESTA	55-200 Hz -10 dB a 1 W/1 m
IMPEDANCIA	Alta Z línea 100 V: 166 Ohm (60 W), 250 Ohm (40 W), 500 Ohm (20 W)
SENSIBILIDAD	89 dB a 1 W/1 m
RED DE CRUCE	Filtro paso bajo, 12 dB/oct.
MATERIAL	ABS y rejilla de acero
COLOR	Blanco grisáceo (RAL 9003, RAL 7047)
MEDIDAS	272 mm Ø x 110 mm fondo
ORIFICIO	240 mm Ø
PESO	2'6 kg
	Sistema de instalación por anclajes



+ Info:
<https://fonestar.com/GAT-80SW>

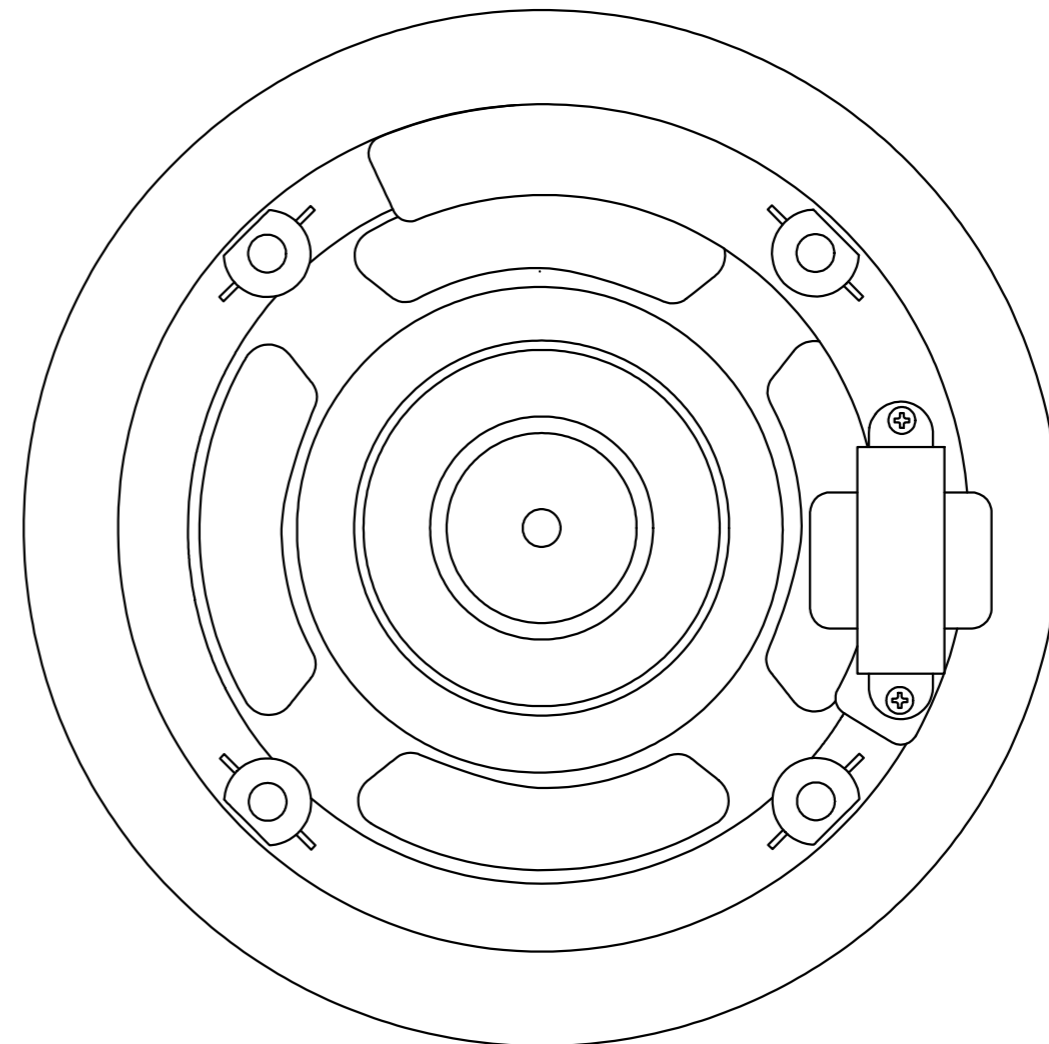
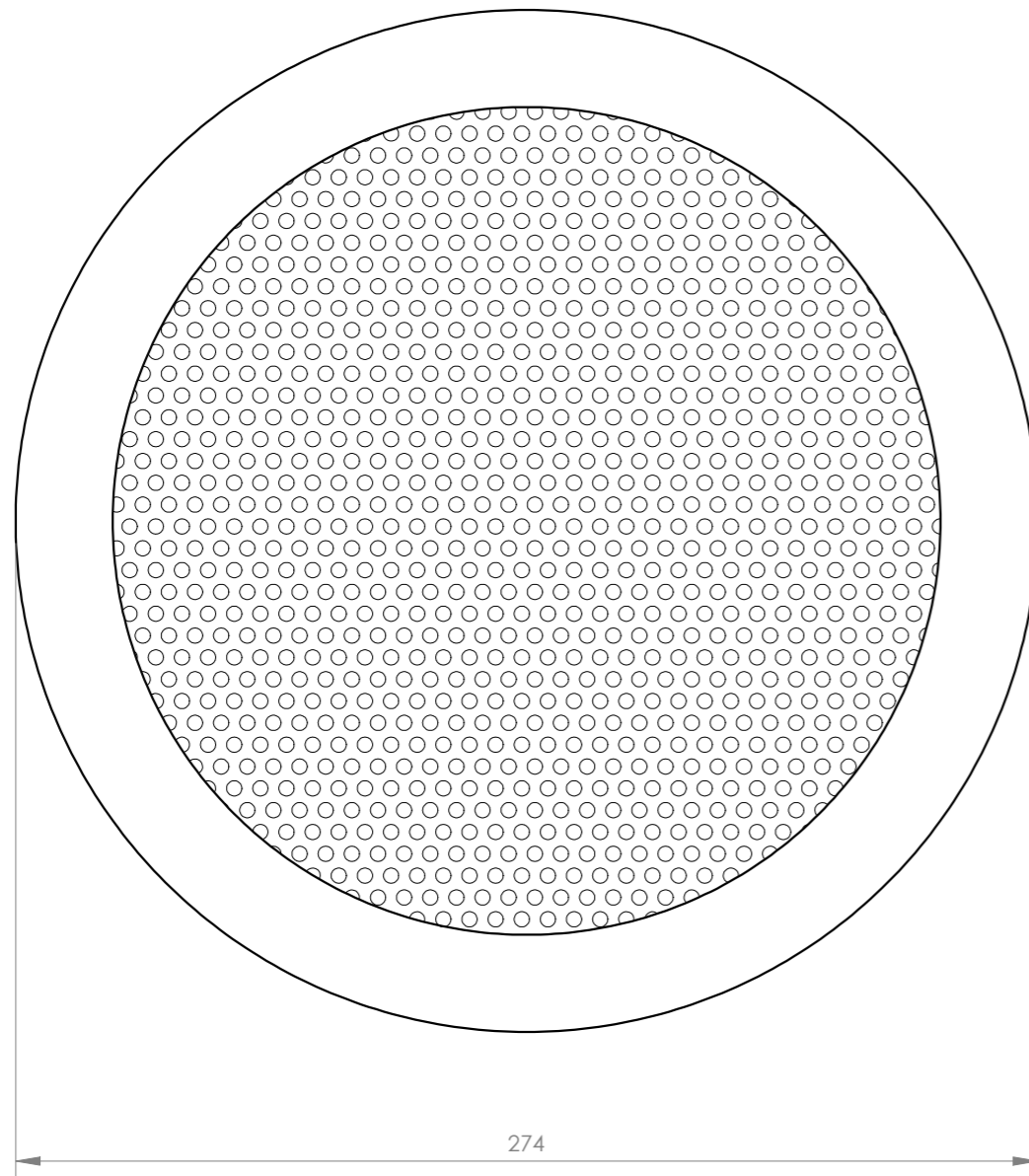
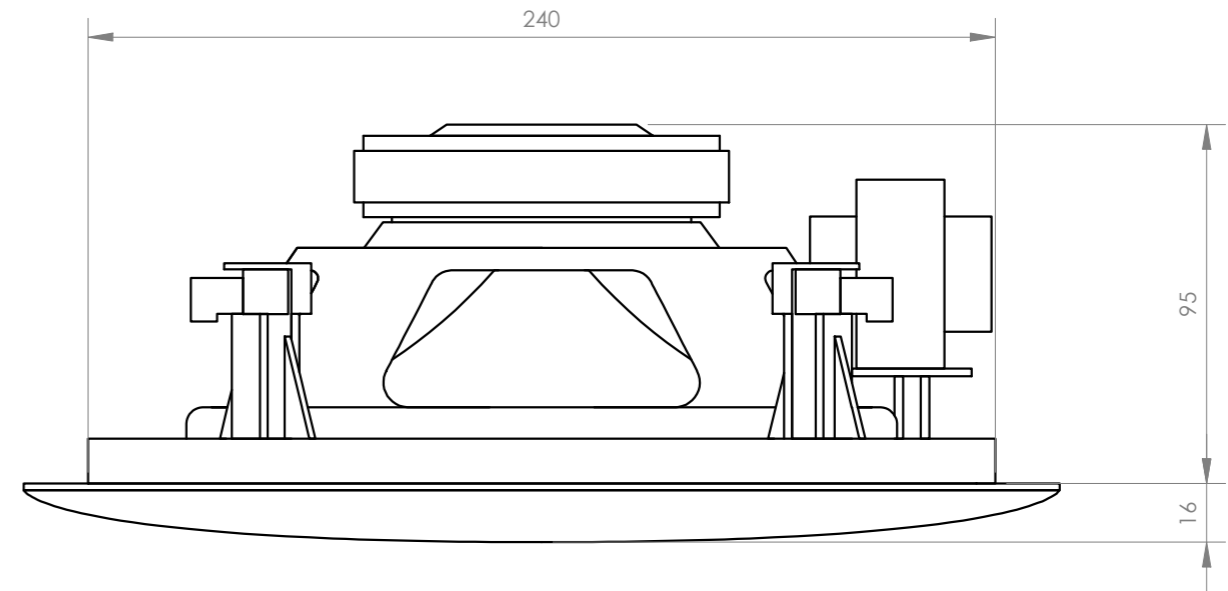

FONESTAR	Model	Description	Units	Scale
	GAT-80SW	100 V LINE TRANSFORMER CEILING SUBWOOFER SPEAKER	mm	1:2