

### Introduction

Follow this document to configure WattBox IP device web interface access using the WattBox-IP Utility. This may be completed in addition to OvrC setup for access to all of the settings in the WattBox IP interface.

### Before You Begin—Firmware Updates

Always check the firmware version of a new WattBox IP before configuring settings in the web interface or OvrC.

- 300, 500, and 700 series models: firmware can be updated using OvrC. Instructions and the firmware files are available directly from OvrC.
- For 200, 400, and 600 series models: firmware must be updated using the WattBox IP utility software or the web interface. Download the newest firmware .zip file from the product support tab at [SnapAV.com](http://SnapAV.com) before continuing.

### Setup Instructions

#### 1. Install the WattBox

Follow the installation manual to complete hardware setup, then follow the directions found on the OvrC QSG to claim the device. Update the firmware using OvrC if a new version is available (300/500/700 models only).

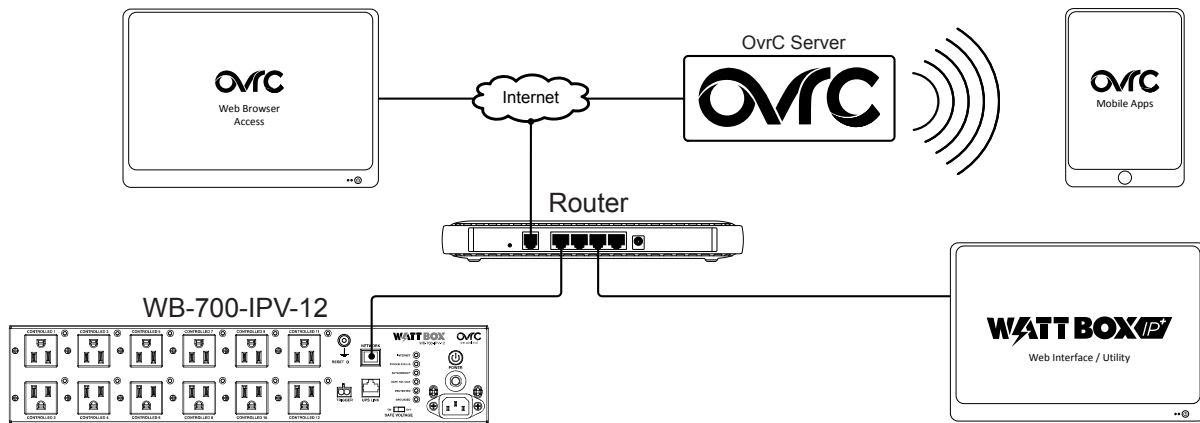

#### 2. Install the WattBox IP Utility Software

Insert the CD included with the WattBox into your PC (utility is not Mac-compatible) and install the software.

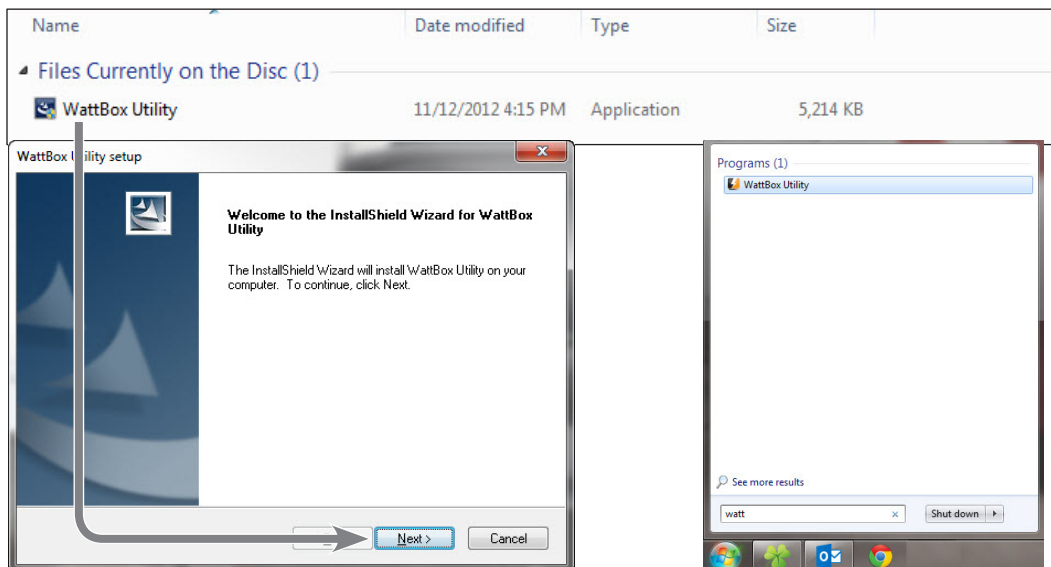

Search "WattBox" in the Start menu search bar to find the installed utility.

### 3. Run the WattBox IP Utility

Close any open VPN connections on your PC, then run the WattBox IP Utility. If prompted, select to run the program as an administrator.

#### WattBox IP Utility Overview

When you run the utility, all WattBox IP-enabled devices on the network will appear in the device list.

The screenshot shows the WattBox Utility web interface. On the left, there is a vertical menu with five orange buttons: 'Launch Web User Interface' (power icon), 'Network Settings' (gears icon), 'Firmware Upgrade' (upward arrow icon), 'About' (info icon), and 'Refresh List' (refresh icon). The main area features the 'WATT BOX' logo at the top. Below the logo is a table with two columns: 'Serial Number' and 'IP Address'. The table contains three rows of data:

Serial Number	IP Address
2432738907	192.168.1.125
3926529161	192.168.1.40
3926565904	192.168.1.41

Below the table is a 'Device Information' section showing details for the selected device (Serial Number: 2432738907, Hardware Version: WB-700-IPV-12, Firmware Version: WB10.5212, LAN IP Address: 192.168.1.125). Callouts point to various elements: 'Launch interface in default web browser' points to the 'Launch Web User Interface' button; 'Change network settings, upgrade firmware, and see device information without logging into the web interface' points to the 'Network Settings', 'Firmware Upgrade', and 'About' buttons; 'Change network settings' points to the 'Refresh List' button; 'Single-click a device to highlight it for editing (Ctrl+Click to select multiple items for firmware upgrade)' points to the first row in the table; and 'Current info about selected device' points to the 'Device Information' section.

### 4. Update Firmware Version (if applicable)

Highlight one or more devices in the list and click the Firmware Upgrade button to open the menu. Browse to find the downloaded and unzipped firmware file, then click Download to begin the update. The devices will automatically reboot after update.

The screenshot shows the WattBox Utility web interface with the 'Firmware Upgrade' dialog box open. The dialog box has a 'File name:' field, a warning message: 'Backup settings before updating the firmware as the update will overwrite all settings to factory default.', and a table with two columns: 'Device' and 'Download Status'. The table contains one row with the device ID '2432738907'. Below the table are 'Download' and 'Cancel' buttons. Callouts explain the process: 'Click to upgrade firmware in selected devices' points to the 'Firmware Upgrade' button in the main interface; 'Click to browse for the downloaded firmware file' points to the 'File name:' field; and 'Click Download to upgrade to the selected file' points to the 'Download' button in the dialog box.

### 5. Configure IP Settings

Set up a static IP address that will ensure the WattBox IP web interface remains accessible after setup and (optionally) set a custom HTTP or telnet port for off-site access. Port forwarding setup must also be completed in the router for offsite access. Click the Network Settings Button to open the menu and begin.

#### IP Address

Select to edit IP address settings

Click to apply settings to device

IP Address: user-created  
Subnet Mask: 255.255.255.0  
Gateway: Router IP address

#### HTTP Port

Check to enable HTTP  
(no web interface access with HTTP disabled)

Enter a custom HTTP port (default: 80)

Click to apply settings to device

### 6. Log in to the WB-IP Web Interface

Click Launch Web User Interface to open the WB-IP login screen in your web browser. Enter the default credentials to log in:

- Username: admin
- Password: \_\_\_\_\_ (no default, leave empty)



### 7. Configure System Time

The default time zone setting must be changed to match the installed location so that scheduled events and log records are correct. Click System Time in the Settings menu and select the correct time zone from the dropdown, then click the Apply button to save the setting.



**CONTROL**  
Control / Status

**SETTINGS**  
Configuration  
Schedule  
Network  
E-mail  
Account  
**System Time**

**LOGS**  
Event Log

**INFORMATION**  
About  
System Status  
Save / Restore

### SYSTEM TIME

**Date and Time Settings [Help]**

Current Time: 2015/03/23 15:53:14 Update now

Time Between Automatic Updates: 1 Hour

Time Server: time.nist.gov Edit

Time Zone: (GMT-5:00) Eastern Time (US & Canada) Relative to GMT Apply

Manual Time Entry: Apply

**Daylight Saving Time [Help]**

Use Daylight Savings Time: (GMT-5:00) Eastern Time (US & Canada) Apply

DST begin: Apply

DST end: Apply

### 8. Change the Default Login Password

Click Account in the Settings menu and change the default admin credentials to avoid unauthorized access to the web interface. After clicking Apply to save the settings you will be asked to log in using the new credentials.

Additional accounts may be created as either an admin (full privileges) or user (can't change settings, can view and control outlets). Be sure to record the login credentials and the purpose of each account in a safe place.



**CONTROL**  
Control / Status

**SETTINGS**  
Configuration  
Schedule  
Network  
E-mail  
Account  
**System Time**

**LOGS**  
Event Log

**INFORMATION**  
About  
System Status  
Save / Restore

### ACCOUNT

**Account Settings [Help]**

Permission	Login	Password	Confirm Password
Administrator	admin	.....	
None			
None			
None			
None			
None			
None			
None			
None			
None			

Apply Reset

**What to Do Next**

After completing the steps in this Quick Start Guide, your device is ready to use. See the full product manual for issues or instructions related to hardware and physical connections. See the WattBox IP interface guide to configure the advanced scheduling and monitoring features available in the web interface.

**Contacting Technical Support**

Phone: 866.838.5052

Email: [TechSupport@SnapAV.com](mailto:TechSupport@SnapAV.com)