

# Product Data Sheet

## Evolve™ Hybrid Rack System 2.0 Base with Casters



SR-EHR2-CASTERBASE

### Package Contents

- A Caster base
- B 4x Bolts
- C 4x Washers

### Key Features

- Fine floor casters
- 400lbs max load

### Installation

1. Remove any equipment from the rack before installing the caster base.
2. Remove the plastic EZ glide runners from the bottom of the rack.
3. Remove the knockouts from the four caster base mounting holes in the bottom of the rack.
4. Use the included bolts and washers to fasten the rack to the base as illustrated. Hand-tighten the bolts using a Phillips screwdriver.
5. Installation is complete. Reinstall equipment in the rack.

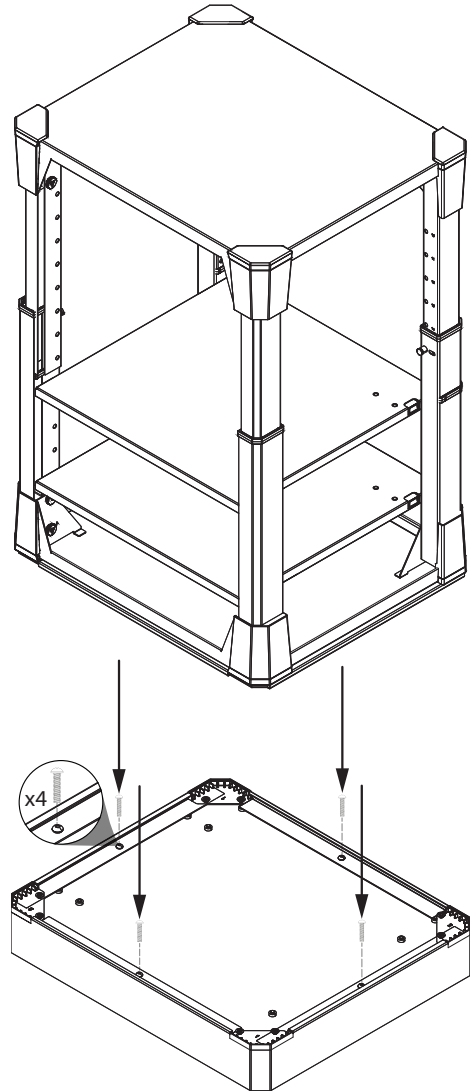
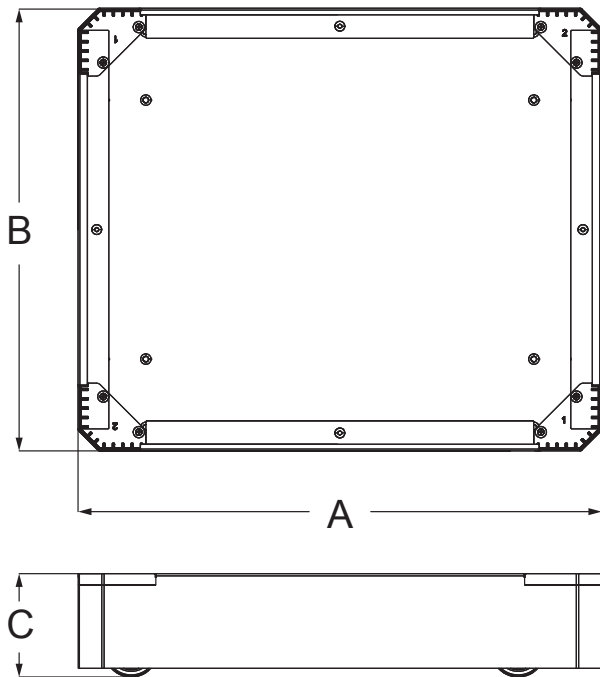

Product	Construction	A - Width	B - Depth	C - Height	Max Load Capacity
SR-EHR2-CASTERBASE	Steel with Deep Black Powder Coat	22"	18.75"	4.25"	400lbs



### Lifetime Limited Warranty

All Strong™ products have a Lifetime Limited Warranty. This warranty includes parts and labor repairs on all components found to be defective in material or workmanship under normal conditions of use. This warranty shall not apply to products that have been abused, modified, or disassembled. Products to be repaired under this warranty must be returned to SnapAV or a designated service center with prior notification and an assigned return authorization number (RA).

For Technical Support: 1.866.838.5052